

Ciências
ULisboa

The Navier-Stokes equation

Margarida Telo da Gama
Rodrigo Coelho

FMC-2024/25

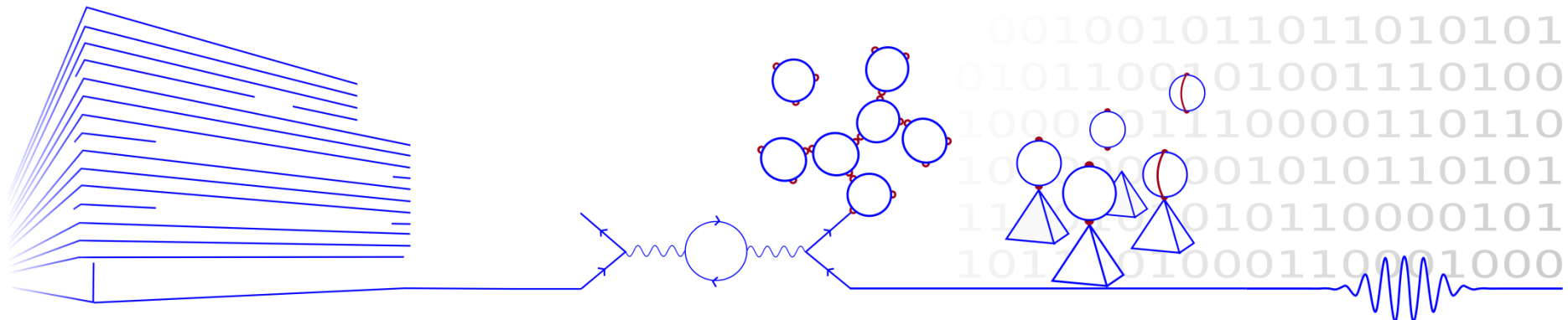

Overview



Understanding the derivation of the differential linear momentum equation for incompressible Newtonian fluids – the Navier-Stokes equation.



This is a set of partial differential equations that are valid at any point in the flow.



When solved, together with the continuity equation, these equations yield details about the velocity, density, pressure, etc., at every point throughout the entire flow domain.



From these fields, by integration, we can find the gross features of the flow such as the net force on the walls or on immersed bodies.



Obtaining analytical solutions of the equation of motion for simple flow fields.



Derivation of the Stokes equation for creeping flow. Obtaining the drag force on a sphere in a uniform stream.



Other applications of the Stoke's equation.

*All models are wrong
but some are useful*



George E.P. Box

Newtonian fluids

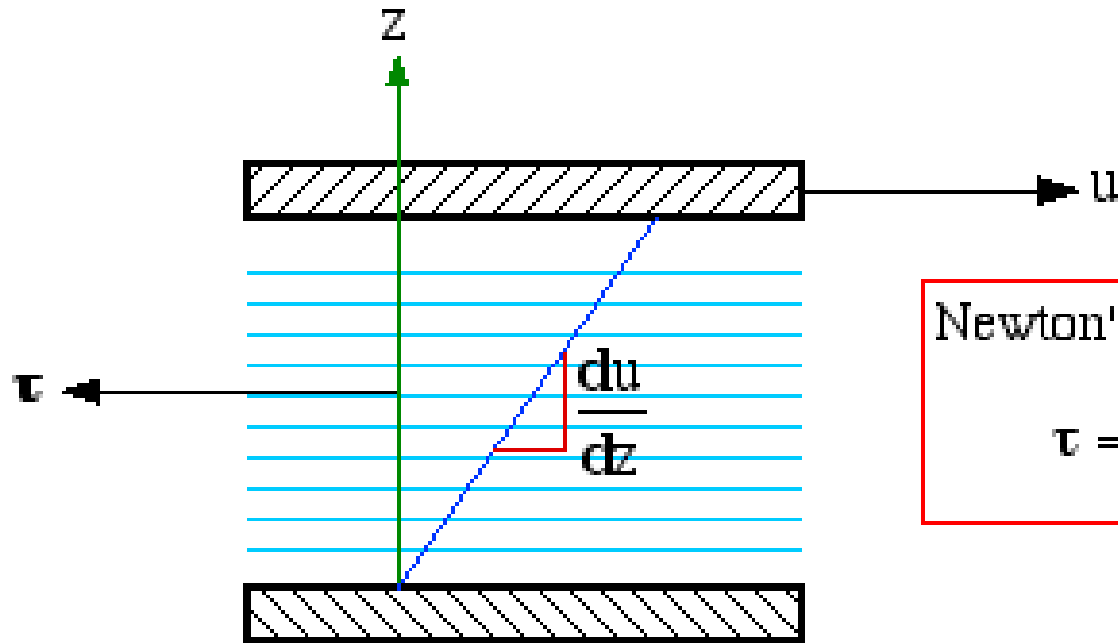

Newton's law of viscosity:

$$\tau = -\mu \frac{du}{dz}$$

Newtonian and non-Newtonian fluids

- Newtonian fluids, defined as fluids for which the shear stress is linearly proportional to the shear strain rate. Many common fluids, such as air and other gases, water, kerosene, gasoline, and other oil-based liquids, are Newtonian fluids.
- Fluids for which the shear stress is not linearly related to the shear strain rate are called non-Newtonian fluids. Examples include slurries and colloidal suspensions, polymer solutions, blood, paste, and cake batter.

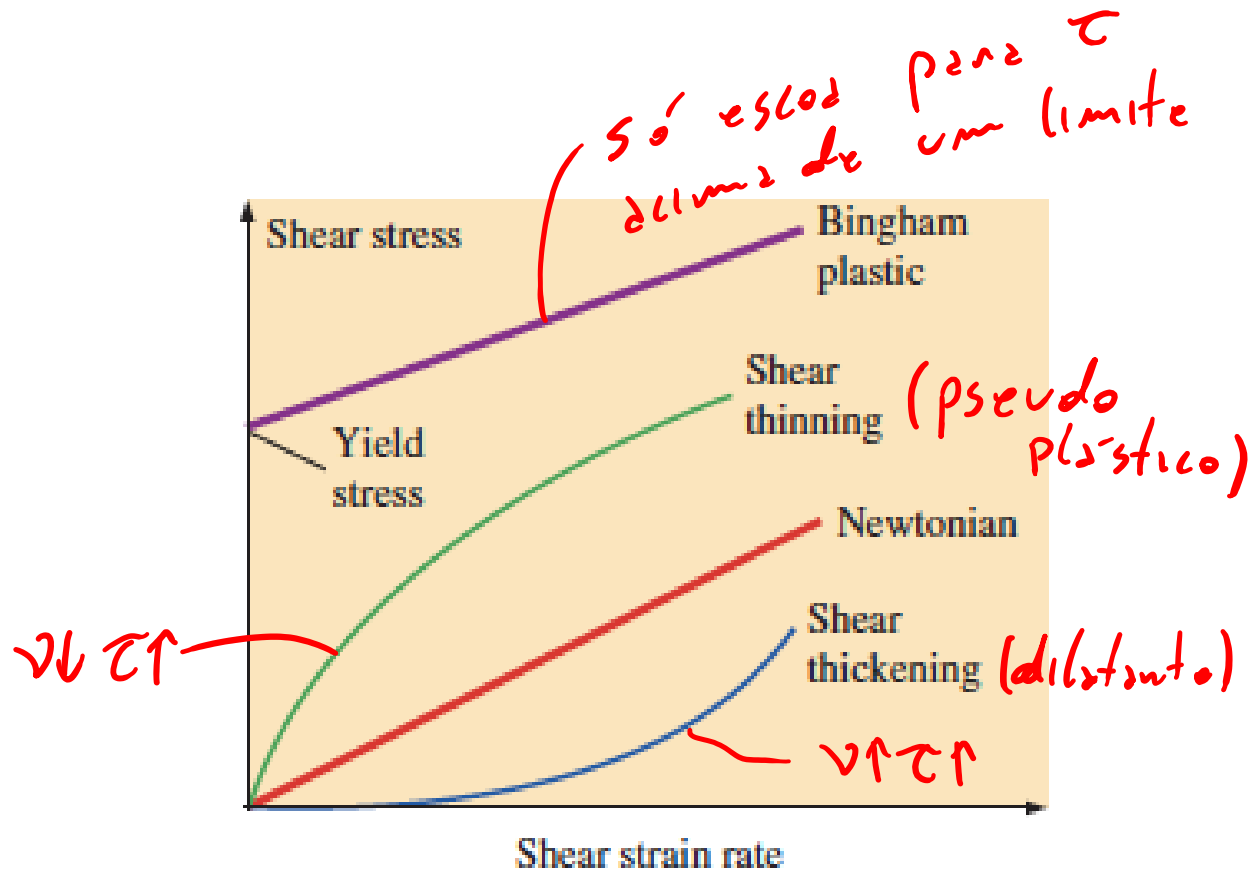

Toothpaste: Bingham plastic



Ketchup: shear thinning (pseudoplastic)



https://www.youtube.com/watch?v=2mYHGn_Pd5M&t=143s

Cornstarch: shear thickening (dilatante) Honey: viscous Newtonian fluid



Viscoelastic fluids with no strings attached

Dispensing a fluid is quick and clean when the nozzle is rotated. The fluid's elastic properties are the reason why.

If you've ever wielded a glue gun, you likely dealt with the wisps of glue that trailed after it. The same issue plagues additive manufacturing: Instead of a tidy reproduction of the desired shape, a three-dimensional printer constructs an object marred by plastic strings, as shown in figure 1. Those strings are difficult to prevent when dispensing plastics, polymers, and other viscoelastic fluids, which behave as viscous fluids at low speeds and as elastic solids at high speeds.

When an ordinary Newtonian fluid such as water is dispensed from above, it bridges the gap between the target substrate and the nozzle. If the gap is kept below a critical value, the connection is stable. At or above that value, gravity gradually drains the liquid until the bridge breaks. To speed up the severance, one can simply lift the nozzle to thin the bridge until it splits.

Retraction also expedites the breakup of viscoelastic liquid bridges. But as the

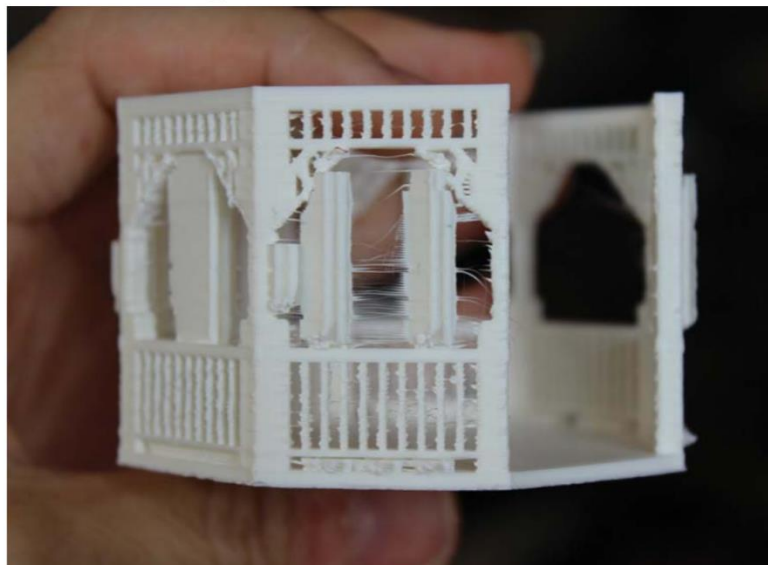
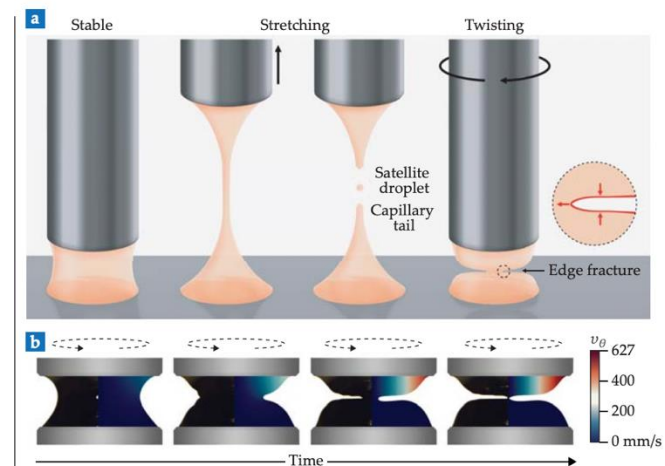

FIGURE 1. PLASTIC STRINGS mar the 3D-printed gazebo shown here. The strings appear when the printer nozzle lifts to detach from the deposited viscoelastic fluid. That retraction elongates the connecting fluid bridge, and after detachment, the strand sticks out. (Photo by Vicky Somma, CC BY-NC-SA 2.0.)



<https://doi.org/10.1063/PT.3.4809>



www.shutterstock.com · 1308961747

Viscosity of Newtonian fluids

Characterizes the degree of internal 'friction'

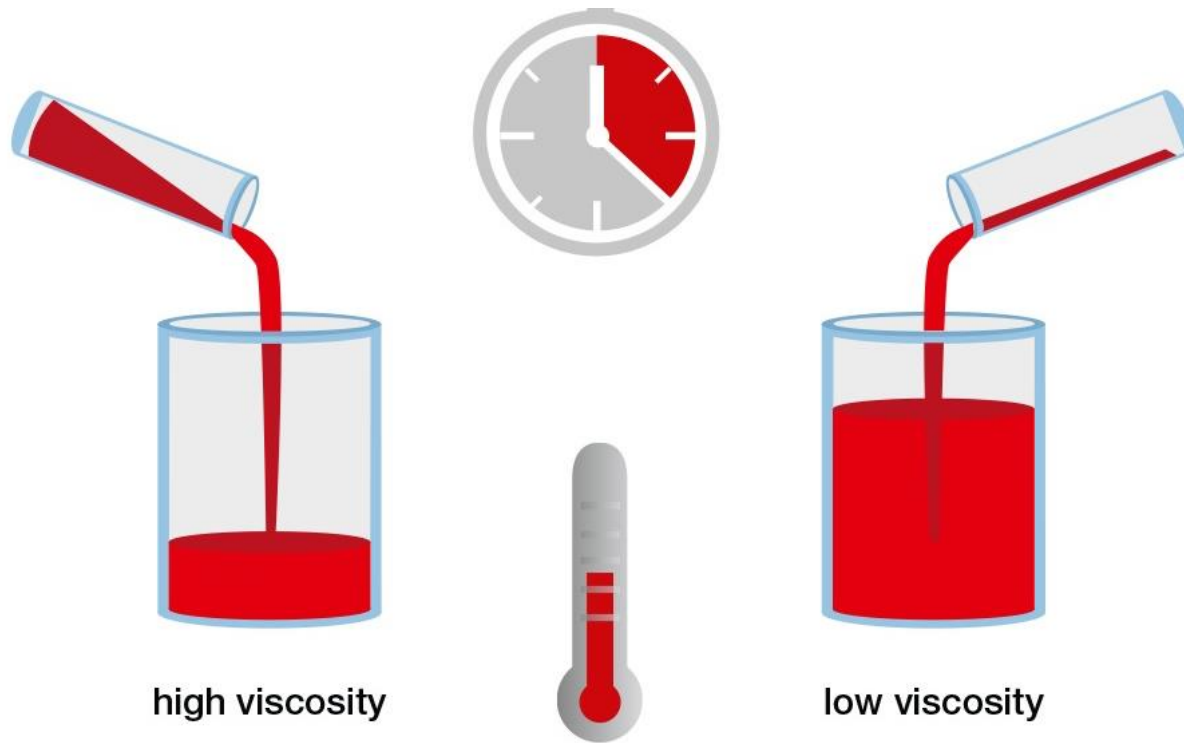

This 'friction', *viscous stress*, is associated with the resistance offered by two adjacent layers of the fluid to their relative motion.

Superfluid

<https://www.youtube.com/watch?v=2Z6UJbwxBZI>



Superfluid helium

Suggested reading: <https://www.scientificamerican.com/article/superfluid-can-climb-walls/>

$$\Rightarrow v \neq 0$$

$$\Rightarrow v = 0$$

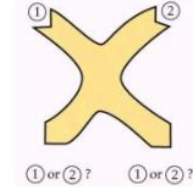
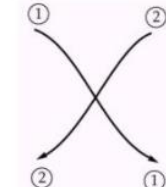
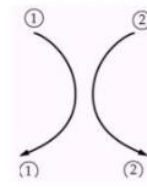

Indistinguishable particles.

Nearly zero viscosity fluids.

Hydrodynamic equations are classical.

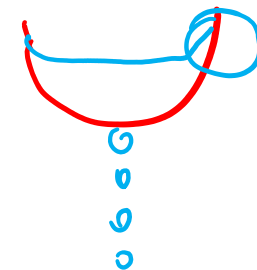

Differential analysis: mass

We start with the conservation of mass, which through the RTT yields the continuity equation

Continuity equation:
$$\frac{\partial \rho}{\partial t} + \vec{\nabla} \cdot (\rho \vec{V}) = 0$$

Alternative form of the continuity equation:

$$\frac{1}{\rho} \frac{D\rho}{Dt} + \vec{\nabla} \cdot \vec{V} = 0$$

Continuity equation in cylindrical coordinates:

$$\frac{\partial \rho}{\partial t} + \frac{1}{r} \frac{\partial (r \rho u_r)}{\partial r} + \frac{1}{r} \frac{\partial (\rho u_\theta)}{\partial \theta} + \frac{\partial (\rho u_z)}{\partial z} = 0$$

Steady continuity equation:

$$\vec{\nabla} \cdot (\rho \vec{V}) = 0$$

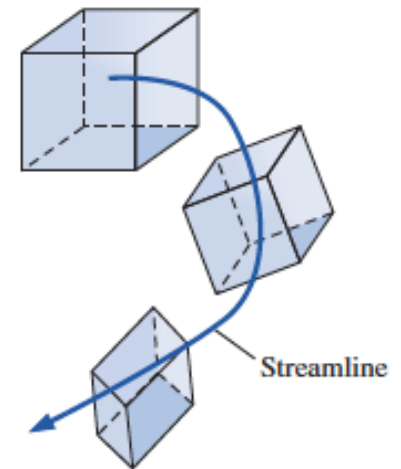

Incompressible continuity equation:

$$\vec{\nabla} \cdot \vec{V} = 0$$

Incompressible continuity equation in Cartesian coordinates:

$$\frac{\partial u}{\partial x} + \frac{\partial v}{\partial y} + \frac{\partial w}{\partial z} = 0$$

Incompressible continuity equation in cylindrical coordinates:

$$\frac{1}{r} \frac{\partial(ru_r)}{\partial r} + \frac{1}{r} \frac{\partial(u_\theta)}{\partial \theta} + \frac{\partial(u_z)}{\partial z} = 0$$

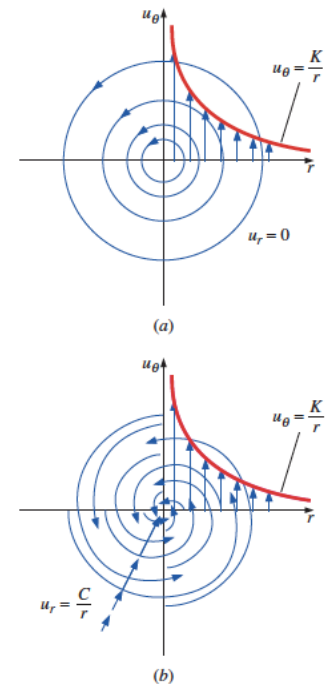

The volumetric strain rate vanishes for incompressible flows.

$$\frac{1}{V} \frac{DV}{Dt} = \varepsilon_{xx} + \varepsilon_{yy} + \varepsilon_{zz} = \frac{\partial u}{\partial x} + \frac{\partial v}{\partial y} + \frac{\partial w}{\partial z}$$

$$\frac{1}{V} \frac{DV}{Dt} = 0$$

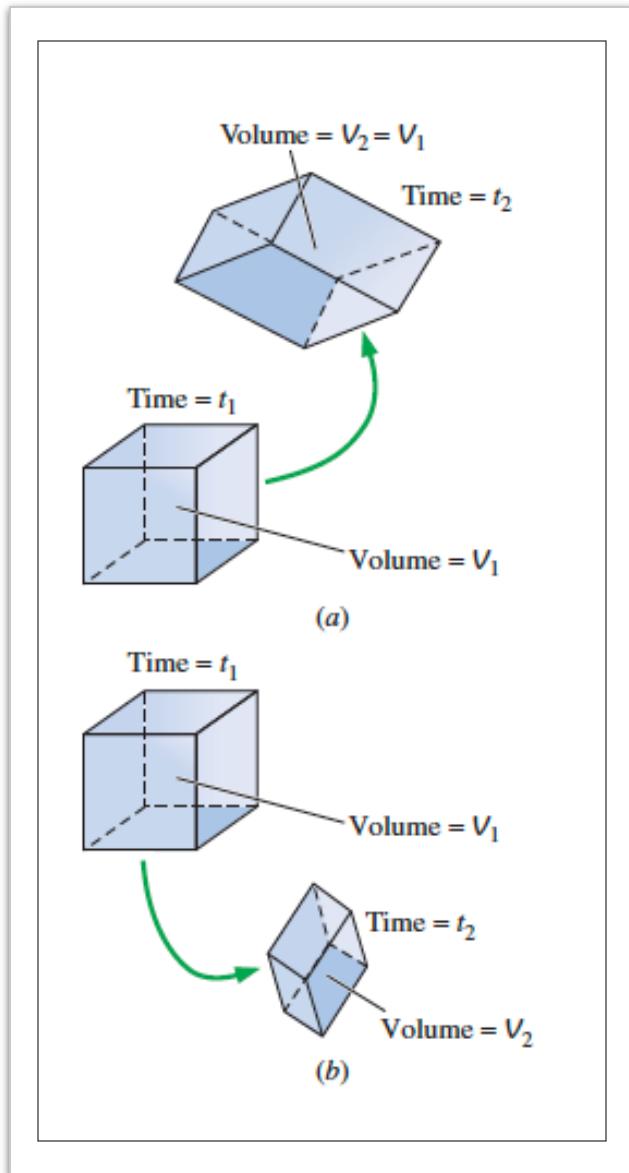

Recall

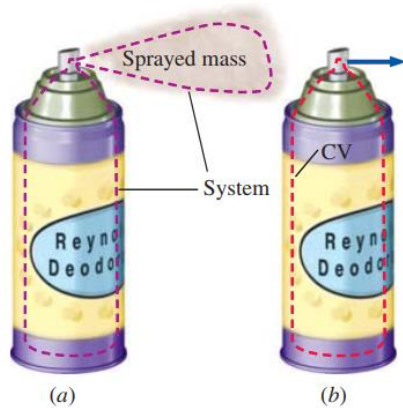

FIGURE 4-53

Two methods of analyzing the spraying of deodorant from a spray can: (a) We follow the fluid as it moves and deforms. This is the *system approach*—no mass crosses the boundary, and the total mass of the system remains fixed. (b) We consider a fixed interior volume of the can. This is the *control volume approach*—mass crosses the boundary.

Reynolds transport theorem (RTT)

$$\frac{dB_{\text{sys}}}{dt} = \int_{\text{CV}} \frac{\partial}{\partial t} (\rho b) dV + \int_{\text{CS}} \rho b \vec{V} \cdot \vec{n} dA$$

Surface force acting on a differential surface element: $d\vec{F}_{\text{surface}} = \sigma_{ij} \cdot \vec{n} dA$

Differential analysis: momentum

- For a control volume the RTT gives the momentum equation:

$$\sum \vec{F} = \int_{CV} \rho \vec{g} dV + \int_{CS} \sigma_{ij} \vec{n} dA = \int_{CV} \frac{\partial}{\partial t} (\rho \vec{V}) dV + \int_{CS} (\rho \vec{V}) \vec{V} \cdot \vec{n} dA$$

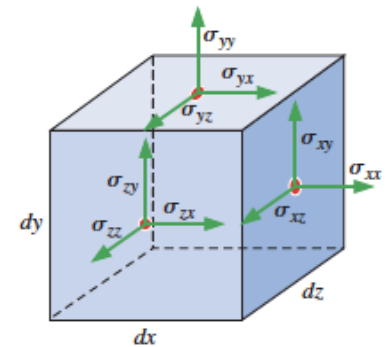

- The total force acting on the control volume is equal to the rate at which momentum changes within the control volume plus the rate at which momentum flows out of the control volume minus the rate at which momentum flows into the control volume.
- The divergence theorem implies that

$$\int_{CS} (\rho \vec{V}) \vec{V} \cdot \vec{n} dA = \int_{CV} \vec{\nabla} \cdot (\rho \vec{V} \vec{V}) dV$$

and

$$\int_{CS} \sigma_{ij} \cdot \vec{n} dA = \int_{CV} \vec{\nabla} \cdot \sigma_{ij} dV$$

- Re-arranging the terms, we find the equation

$$\int_{CV} \left[\frac{\partial}{\partial t} (\rho \vec{V}) + \vec{\nabla} \cdot (\rho \vec{V} \vec{V}) - \rho \vec{g} - \vec{\nabla} \cdot \sigma_{ij} \right] dV = 0$$

valid for any CV and thus, we obtain the Cauchy equation of motion

Cauchy's equation:
$$\frac{\partial}{\partial t} (\rho \vec{V}) + \vec{\nabla} \cdot (\rho \vec{V} \vec{V}) = \rho \vec{g} + \vec{\nabla} \cdot \sigma_{ij}$$

Other derivations are possible, e.g. by starting from an infinitesimal CV.

Alternative form of Cauchy's equation

- Clearly,

$$\frac{\partial}{\partial t}(\rho \vec{V}) = \rho \frac{\partial \vec{V}}{\partial t} + \vec{V} \frac{\partial \rho}{\partial t}$$

- The second term of Cauchy's equation can be written as

$$\vec{\nabla} \cdot (\rho \vec{V} \vec{V}) = \vec{V} \vec{\nabla} \cdot (\rho \vec{V}) + \rho (\vec{V} \cdot \vec{\nabla}) \vec{V}$$

- Substituting this into the Cauchy's equation we find

$$\rho \frac{\partial \vec{V}}{\partial t} + \vec{V} \left[\frac{\partial \rho}{\partial t} + \vec{\nabla} \cdot (\rho \vec{V}) \right] + \rho (\vec{V} \cdot \vec{\nabla}) \vec{V} = \rho \vec{g} + \vec{\nabla} \cdot \sigma_{ij}$$

- The continuity equation implies that the term in brackets vanishes and then

Alternative form of Cauchy's equation:

$$\rho \left[\frac{\partial \vec{V}}{\partial t} + (\vec{V} \cdot \vec{\nabla}) \vec{V} \right] = \rho \frac{D\vec{V}}{Dt} = \rho \vec{g} + \vec{\nabla} \cdot \sigma_{ij}$$

Cauchy's equation in cartesian components

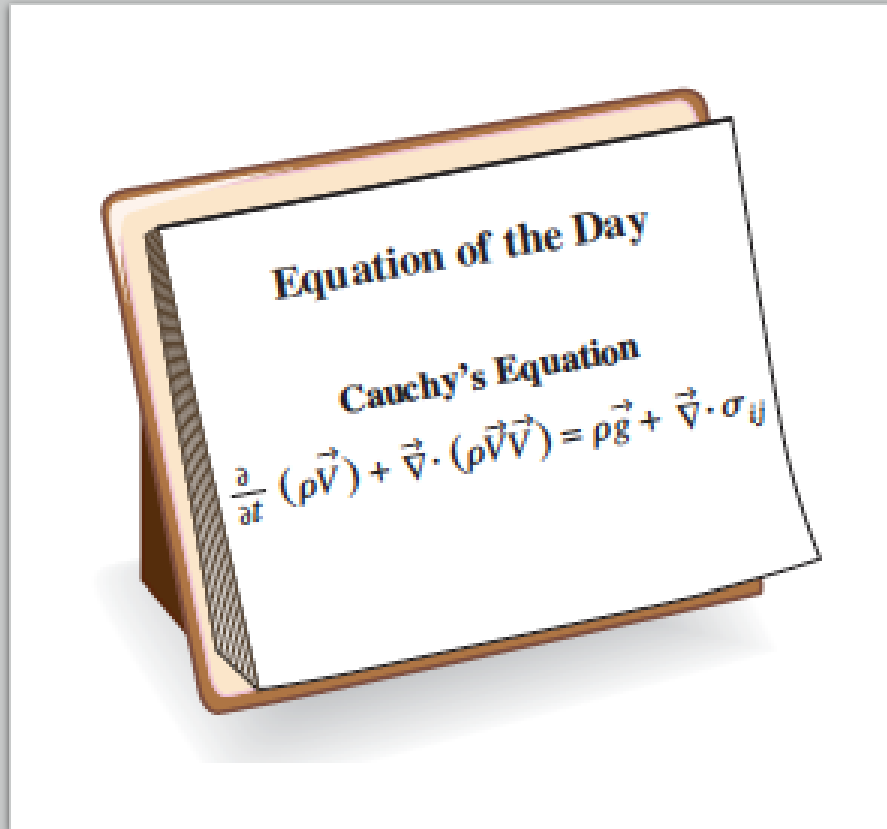

$$\vec{\nabla} \cdot \vec{u} = 0$$

x-component: $\rho \frac{Du}{Dt} = \rho g_x + \frac{\partial \sigma_{xx}}{\partial x} + \frac{\partial \sigma_{yx}}{\partial y} + \frac{\partial \sigma_{zx}}{\partial z}$

y-component: $\rho \frac{Dv}{Dt} = \rho g_y + \frac{\partial \sigma_{xy}}{\partial x} + \frac{\partial \sigma_{yy}}{\partial y} + \frac{\partial \sigma_{zy}}{\partial z}$

z-component: $\rho \frac{Dw}{Dt} = \rho g_z + \frac{\partial \sigma_{xz}}{\partial x} + \frac{\partial \sigma_{yz}}{\partial y} + \frac{\partial \sigma_{zz}}{\partial z}$

The Navier-Stokes equation

- To be mathematically solvable, the number of equations must equal the number of unknowns, and thus we need six more equations.
- These equations are called constitutive equations, and they enable us to write the components of the stress tensor in terms of the velocity and pressure fields.
- The first thing we do is to separate the pressure stresses and the viscous stresses.
- For a fluid at rest

Fluid at rest:

$$\sigma_{ij} = \begin{pmatrix} \sigma_{xx} & \sigma_{xy} & \sigma_{xz} \\ \sigma_{yx} & \sigma_{yy} & \sigma_{yz} \\ \sigma_{zx} & \sigma_{zy} & \sigma_{zz} \end{pmatrix} = \begin{pmatrix} -P & 0 & 0 \\ 0 & -P & 0 \\ 0 & 0 & -P \end{pmatrix}$$

- For moving fluids,

Moving fluids:

$$\sigma_{ij} = \begin{pmatrix} \sigma_{xx} & \sigma_{xy} & \sigma_{xz} \\ \sigma_{yx} & \sigma_{yy} & \sigma_{yz} \\ \sigma_{zx} & \sigma_{zy} & \sigma_{zz} \end{pmatrix} = \begin{pmatrix} -P & 0 & 0 \\ 0 & -P & 0 \\ 0 & 0 & -P \end{pmatrix} + \begin{pmatrix} \tau_{xx} & \tau_{xy} & \tau_{xz} \\ \tau_{yx} & \tau_{yy} & \tau_{yz} \\ \tau_{zx} & \tau_{zy} & \tau_{zz} \end{pmatrix}$$

- where we have introduced a new tensor, τ_{ij} , called the viscous stress tensor or the **deviatoric stress tensor**.
- There are constitutive equations that express τ_{ij} in terms of the velocity field and measurable fluid properties such as the viscosity.
- The actual form of the constitutive relations depends on the type of fluid.
- The stress is Galilean invariant: it does not depend directly on the flow velocity, but only on **spatial derivatives of the flow velocity**. So the stress variable is the tensor gradient ∇u .
- The fluid is assumed to be isotropic, as with gases and simple liquids, and consequently **τ is an isotropic tensor**; furthermore, since the deviatoric stress tensor can be expressed in terms of the dynamic viscosity μ :

Stokes (1845) deduced eqn (6.9) from three elementary hypotheses. On writing $T_{ij} = -p\delta_{ij} + T_{ij}^D$ these amount essentially to:

- (i) each T_{ij}^D should be a linear function of the velocity gradients $\partial u_1/\partial x_1$, $\partial u_1/\partial x_2$, etc.;
- (ii) each T_{ij}^D should vanish if the flow involves no deformation of fluid elements;
- (iii) the relationship between T_{ij}^D and the velocity gradients should be isotropic, as the physical properties of the fluid are assumed to show no preferred direction.

Navier-Stokes equation for incompressible and isothermal flow

Viscous stress tensor for an incompressible Newtonian fluid with constant properties:

$$\tau_{ij} = 2\mu\epsilon_{ij}$$

where μ is the shear viscosity.

In cartesian coordinates, the deviatoric stress tensor becomes

$$\tau_{ij} = \begin{pmatrix} \tau_{xx} & \tau_{xy} & \tau_{xz} \\ \tau_{yx} & \tau_{yy} & \tau_{yz} \\ \tau_{zx} & \tau_{zy} & \tau_{zz} \end{pmatrix} = \begin{pmatrix} 2\mu \frac{\partial u}{\partial x} & \mu \left(\frac{\partial u}{\partial y} + \frac{\partial v}{\partial x} \right) & \mu \left(\frac{\partial u}{\partial z} + \frac{\partial w}{\partial x} \right) \\ \mu \left(\frac{\partial v}{\partial x} + \frac{\partial u}{\partial y} \right) & 2\mu \frac{\partial v}{\partial y} & \mu \left(\frac{\partial v}{\partial z} + \frac{\partial w}{\partial y} \right) \\ \mu \left(\frac{\partial w}{\partial x} + \frac{\partial u}{\partial z} \right) & \mu \left(\frac{\partial w}{\partial y} + \frac{\partial v}{\partial z} \right) & 2\mu \frac{\partial w}{\partial z} \end{pmatrix}$$

Stress tensor for Newtonian fluids

$$\sigma_{ij} = \begin{pmatrix} -P & 0 & 0 \\ 0 & -P & 0 \\ 0 & 0 & -P \end{pmatrix} + \begin{pmatrix} 2\mu \frac{\partial u}{\partial x} & \mu \left(\frac{\partial u}{\partial y} + \frac{\partial v}{\partial x} \right) & \mu \left(\frac{\partial u}{\partial z} + \frac{\partial w}{\partial x} \right) \\ \mu \left(\frac{\partial v}{\partial x} + \frac{\partial u}{\partial y} \right) & 2\mu \frac{\partial v}{\partial y} & \mu \left(\frac{\partial v}{\partial z} + \frac{\partial w}{\partial y} \right) \\ \mu \left(\frac{\partial w}{\partial x} + \frac{\partial u}{\partial z} \right) & \mu \left(\frac{\partial w}{\partial y} + \frac{\partial v}{\partial z} \right) & 2\mu \frac{\partial w}{\partial z} \end{pmatrix}$$

Substituting this into Cauchy's equation we find, in the x direction:

$$\rho \frac{Du}{Dt} = -\frac{\partial P}{\partial x} + \rho g_x + 2\mu \frac{\partial^2 u}{\partial x^2} + \mu \frac{\partial}{\partial y} \left(\frac{\partial v}{\partial x} + \frac{\partial u}{\partial y} \right) + \mu \frac{\partial}{\partial z} \left(\frac{\partial w}{\partial x} + \frac{\partial u}{\partial z} \right)$$

We note that as long as the velocity components are smooth functions of x , y , and z , the order of differentiation is irrelevant. For example, the first part of the last term above can be rewritten as

$$\mu \frac{\partial}{\partial z} \left(\frac{\partial w}{\partial x} \right) = \mu \frac{\partial}{\partial x} \left(\frac{\partial w}{\partial z} \right)$$

After some (clever) re-arrangements of the viscous terms we find

$$\begin{aligned}\rho \frac{Du}{Dt} &= -\frac{\partial P}{\partial x} + \rho g_x + \mu \left[\frac{\partial^2 u}{\partial x^2} + \frac{\partial}{\partial x} \frac{\partial u}{\partial x} + \frac{\partial}{\partial x} \frac{\partial v}{\partial y} + \frac{\partial^2 u}{\partial y^2} + \frac{\partial}{\partial x} \frac{\partial w}{\partial z} + \frac{\partial^2 u}{\partial z^2} \right] \\ &= -\frac{\partial P}{\partial x} + \rho g_x + \mu \left[\frac{\partial}{\partial x} \left(\frac{\partial u}{\partial x} + \frac{\partial v}{\partial y} + \frac{\partial w}{\partial z} \right) + \frac{\partial^2 u}{\partial x^2} + \frac{\partial^2 u}{\partial y^2} + \frac{\partial^2 u}{\partial z^2} \right]\end{aligned}$$

and thus

$$\rho \frac{Du}{Dt} = -\frac{\partial P}{\partial x} + \rho g_x + \mu \nabla^2 u$$

Similarly,

$$\rho \frac{Dv}{Dt} = -\frac{\partial P}{\partial y} + \rho g_y + \mu \nabla^2 v$$

$$\rho \frac{Dw}{Dt} = -\frac{\partial P}{\partial z} + \rho g_z + \mu \nabla^2 w$$

Incompressible Navier–Stokes equation:

$$\rho \frac{D\vec{V}}{Dt} = -\vec{\nabla} P + \rho \vec{g} + \mu \nabla^2 \vec{V}$$

Cartesian coordinates

Incompressible continuity equation:

$$\frac{\partial u}{\partial x} + \frac{\partial v}{\partial y} + \frac{\partial w}{\partial z} = 0$$

x-component of the incompressible Navier–Stokes equation:

$$\rho \left(\frac{\partial u}{\partial t} + u \frac{\partial u}{\partial x} + v \frac{\partial u}{\partial y} + w \frac{\partial u}{\partial z} \right) = -\frac{\partial P}{\partial x} + \rho g_x + \mu \left(\frac{\partial^2 u}{\partial x^2} + \frac{\partial^2 u}{\partial y^2} + \frac{\partial^2 u}{\partial z^2} \right)$$

y-component of the incompressible Navier–Stokes equation:

$$\rho \left(\frac{\partial v}{\partial t} + u \frac{\partial v}{\partial x} + v \frac{\partial v}{\partial y} + w \frac{\partial v}{\partial z} \right) = -\frac{\partial P}{\partial y} + \rho g_y + \mu \left(\frac{\partial^2 v}{\partial x^2} + \frac{\partial^2 v}{\partial y^2} + \frac{\partial^2 v}{\partial z^2} \right)$$

z-component of the incompressible Navier–Stokes equation:

$$\rho \left(\frac{\partial w}{\partial t} + u \frac{\partial w}{\partial x} + v \frac{\partial w}{\partial y} + w \frac{\partial w}{\partial z} \right) = -\frac{\partial P}{\partial z} + \rho g_z + \mu \left(\frac{\partial^2 w}{\partial x^2} + \frac{\partial^2 w}{\partial y^2} + \frac{\partial^2 w}{\partial z^2} \right)$$

Cylindrical coordinates

Incompressible continuity equation:
$$\frac{1}{r} \frac{\partial(ru_r)}{\partial r} + \frac{1}{r} \frac{\partial(u_\theta)}{\partial \theta} + \frac{\partial(u_z)}{\partial z} = 0$$

r-component of the incompressible Navier–Stokes equation:

$$\begin{aligned} & \rho \left(\frac{\partial u_r}{\partial t} + u_r \frac{\partial u_r}{\partial r} + \frac{u_\theta}{r} \frac{\partial u_r}{\partial \theta} - \frac{u_\theta^2}{r} + u_z \frac{\partial u_r}{\partial z} \right) \\ &= -\frac{\partial P}{\partial r} + \rho g_r + \mu \left[\frac{1}{r} \frac{\partial}{\partial r} \left(r \frac{\partial u_r}{\partial r} \right) - \frac{u_r}{r^2} + \frac{1}{r^2} \frac{\partial^2 u_r}{\partial \theta^2} - \frac{2}{r^2} \frac{\partial u_\theta}{\partial \theta} + \frac{\partial^2 u_r}{\partial z^2} \right] \end{aligned}$$

θ -component of the incompressible Navier–Stokes equation:

$$\begin{aligned} & \rho \left(\frac{\partial u_\theta}{\partial t} + u_r \frac{\partial u_\theta}{\partial r} + \frac{u_\theta}{r} \frac{\partial u_\theta}{\partial \theta} + \frac{u_r u_\theta}{r} + u_z \frac{\partial u_\theta}{\partial z} \right) \\ &= -\frac{1}{r} \frac{\partial P}{\partial \theta} + \rho g_\theta + \mu \left[\frac{1}{r} \frac{\partial}{\partial r} \left(r \frac{\partial u_\theta}{\partial r} \right) - \frac{u_\theta}{r^2} + \frac{1}{r^2} \frac{\partial^2 u_\theta}{\partial \theta^2} + \frac{2}{r^2} \frac{\partial u_r}{\partial \theta} + \frac{\partial^2 u_\theta}{\partial z^2} \right] \end{aligned}$$

z-component of the incompressible Navier–Stokes equation:

$$\begin{aligned} & \rho \left(\frac{\partial u_z}{\partial t} + u_r \frac{\partial u_z}{\partial r} + \frac{u_\theta}{r} \frac{\partial u_z}{\partial \theta} + u_z \frac{\partial u_z}{\partial z} \right) \\ &= -\frac{\partial P}{\partial z} + \rho g_z + \mu \left[\frac{1}{r} \frac{\partial}{\partial r} \left(r \frac{\partial u_z}{\partial r} \right) + \frac{1}{r^2} \frac{\partial^2 u_z}{\partial \theta^2} + \frac{\partial^2 u_z}{\partial z^2} \right] \end{aligned}$$

Viscous stress tensor in cylindrical coordinates

$$\tau_{ij} = \begin{pmatrix} \tau_{rr} & \tau_{r\theta} & \tau_{rz} \\ \tau_{\theta r} & \tau_{\theta\theta} & \tau_{\theta z} \\ \tau_{zr} & \tau_{z\theta} & \tau_{zz} \end{pmatrix}$$

$$= \begin{pmatrix} 2\mu \frac{\partial u_r}{\partial r} & \mu \left[r \frac{\partial}{\partial r} \left(\frac{u_\theta}{r} \right) + \frac{1}{r} \frac{\partial u_r}{\partial \theta} \right] & \mu \left(\frac{\partial u_r}{\partial z} + \frac{\partial u_z}{\partial r} \right) \\ \mu \left[r \frac{\partial}{\partial r} \left(\frac{u_\theta}{r} \right) + \frac{1}{r} \frac{\partial u_r}{\partial \theta} \right] & 2\mu \left(\frac{1}{r} \frac{\partial u_\theta}{\partial \theta} + \frac{u_r}{r} \right) & \mu \left(\frac{\partial u_\theta}{\partial z} + \frac{1}{r} \frac{\partial u_z}{\partial \theta} \right) \\ \mu \left(\frac{\partial u_r}{\partial z} + \frac{\partial u_z}{\partial r} \right) & \mu \left(\frac{\partial u_\theta}{\partial z} + \frac{1}{r} \frac{\partial u_z}{\partial \theta} \right) & 2\mu \frac{\partial u_z}{\partial z} \end{pmatrix}$$

Alternative derivation of the Navier-Stokes equation (skip on a first reading)

- It can be shown (Faber page 196-198) that the isotropy of the fluid, the symmetry of the shear stress and the linearity between stress and strain rate imply,

$$p_1 = p - \frac{2}{3} \eta \left(2 \frac{\partial u_1}{\partial x_1} - \frac{\partial u_2}{\partial x_2} - \frac{\partial u_3}{\partial x_3} \right),$$

where

$$3p = p'_1 + p'_2 + p'_3 = p_1 + p_2 + p_3.$$

with similar equations for 2 and 3.

- For incompressible fluids, the equations may be re-written,

$$p_1 = p - 2\eta \frac{\partial u_1}{\partial x_1},$$

or else that

$$p_1 = p + 2\eta \left(\frac{\partial u_2}{\partial x_2} + \frac{\partial u_3}{\partial x_3} \right).$$

Now any second-rank tensor may be expressed as the sum of three parts, one of which is isotropic in character and the other two anisotropic. The two anisotropic parts are traceless tensors (the word 'traceless' means in this context that when the tensors' components are written out in matrix form the diagonal ones sum to zero), one of them symmetric and the other antisymmetric; the components of the antisymmetric part change sign when the reference axes are reflected (i.e. when they are labelled according to the left-handed convention instead of the right-handed one, or *vice versa*), but the components of the symmetric part are unaffected by reflection. The stress tensor, for example, may be divided thus:

$$\sigma_{ij} = \frac{1}{3} \delta_{ij} \sigma_{mm} + \frac{1}{2} \left(\sigma_{ij} + \sigma_{ji} - \frac{2}{3} \delta_{ij} \sigma_{mm} \right) + \frac{1}{2} \left(\sigma_{ij} - \sigma_{ji} \right),$$

where, according to the standard summation convention for repeated dummy suffices,

$$\sigma_{mm} = \sigma_{11} + \sigma_{22} + \sigma_{33} = -3p;$$

we may write the symmetric anisotropic part of the stress tensor –

$$\sigma_{ij} + \delta_{ij} p = q_{ij} \text{ (say),}$$

while the antisymmetric anisotropic part – the third term – evidently vanishes.

If the rate of deformation tensor is divided in this way its isotropic part turns out to be

$$\frac{1}{3} \delta_{ij} \frac{\partial u_m}{\partial x_m} \left[\equiv \frac{1}{3} \delta_{ij} \nabla \cdot \mathbf{u} \right],$$

while its symmetric and antisymmetric anisotropic parts are respectively

$$\frac{1}{2} \left(\frac{\partial u_i}{\partial x_j} + \frac{\partial u_j}{\partial x_i} - \frac{2}{3} \delta_{ij} \frac{\partial u_m}{\partial x_m} \right) = \zeta_{ij} \text{ (say)}$$

and

$$\frac{1}{2} \left(\frac{\partial u_i}{\partial x_j} - \frac{\partial u_j}{\partial x_i} \right) = \omega_{ij} \text{ (say)}.$$

The symbol ω is appropriate in (6.19) because what ω_{ij} describes on its own is the local rate of rotation of the medium; its six non-zero components are the components of the vectors $+\frac{1}{2}\boldsymbol{\Omega}$ and $-\frac{1}{2}\boldsymbol{\Omega}$, where $\boldsymbol{\Omega}$ is the vorticity. What ζ_{ij} describes on its own is a type of shear flow which is vorticity-free.

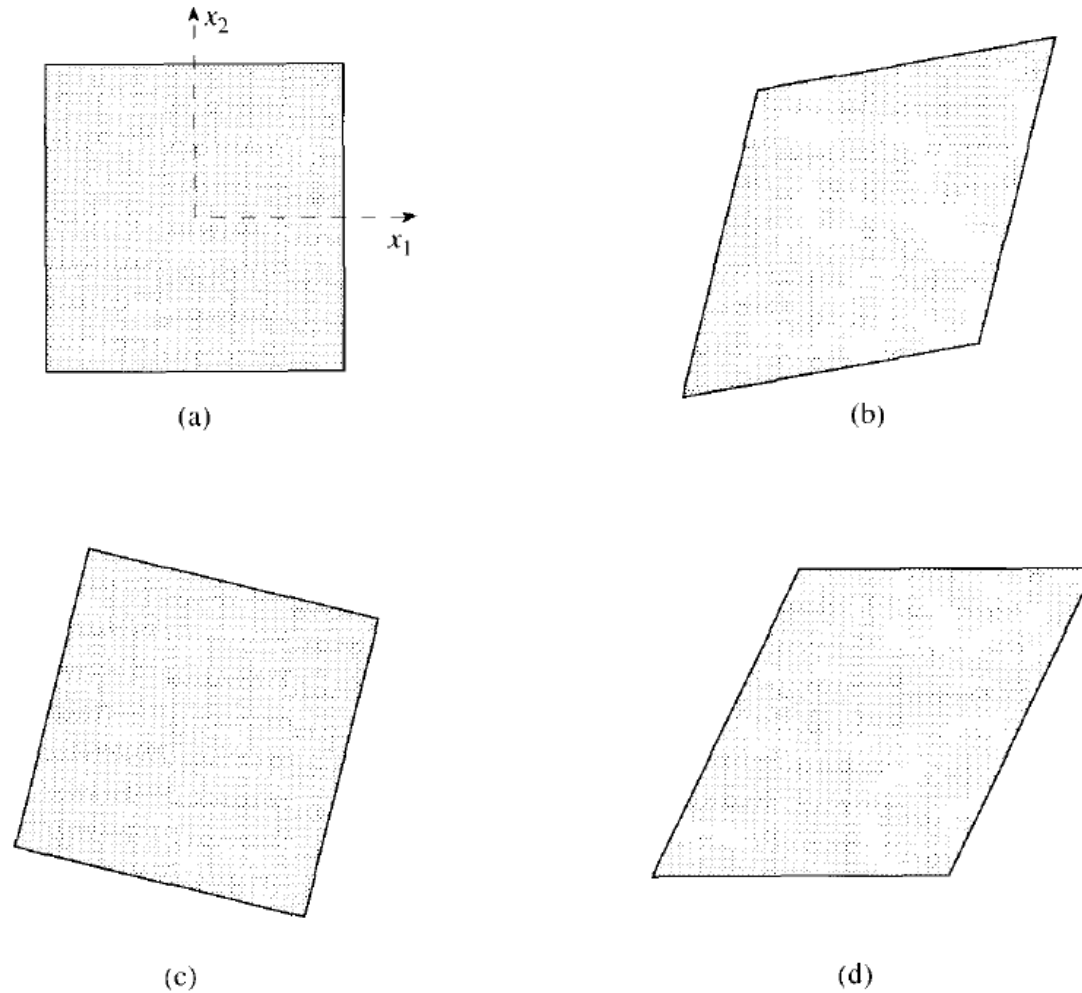

Figure 6.3 The effect on the square fluid element shown in (a) of (b) vorticity-free shear ($\zeta_{12} > 0$, $\omega_{12} = 0$), (c) pure rotation ($\zeta_{12} = 0$, $\omega_{12} > 0$), and (d) an equal combination of the two ($\zeta_{12} = \omega_{12} > 0$).

Where one second-rank tensor depends upon another in a linear fashion, the coefficient is a fourth-rank tensor which in general may have up to 81 independent components. However, the fourth-rank tensor which relates stress to rate of deformation in a Newtonian fluid must be isotropic if the fluid itself is isotropic, and this greatly reduces its complexity. It turns out that each of the three parts of the stress tensor must then be separately related in a linear fashion to the corresponding part of the rate of deformation tensor, and that the coefficient is in each case a scalar. For example, we must expect

$$\frac{1}{2} (\sigma_{ij} - \sigma_{ji}) \propto \omega_{ij}.$$

In this case the scalar coefficient of proportionality must be zero because the antisymmetric part of the stress is always zero, and this is no surprise; local rotation does not change the separation between any two points embedded in the fluid an infinitesimal distance apart, so there is no reason to expect it to give rise to stress. More significantly, we must expect q_{ij} to be proportional to ζ_{ij} , and by choosing the constant of proportionality to be 2η we arrive at once,

$$s_{ij} = \eta \left(\frac{\partial u_i}{\partial x_j} + \frac{\partial u_j}{\partial x_i} \right); \quad -p_i + p = \eta \left(2 \frac{\partial u_i}{\partial x_i} - \frac{2}{3} \frac{\partial u_m}{\partial x_m} \right).$$

Total force on a fluid element (component 1)

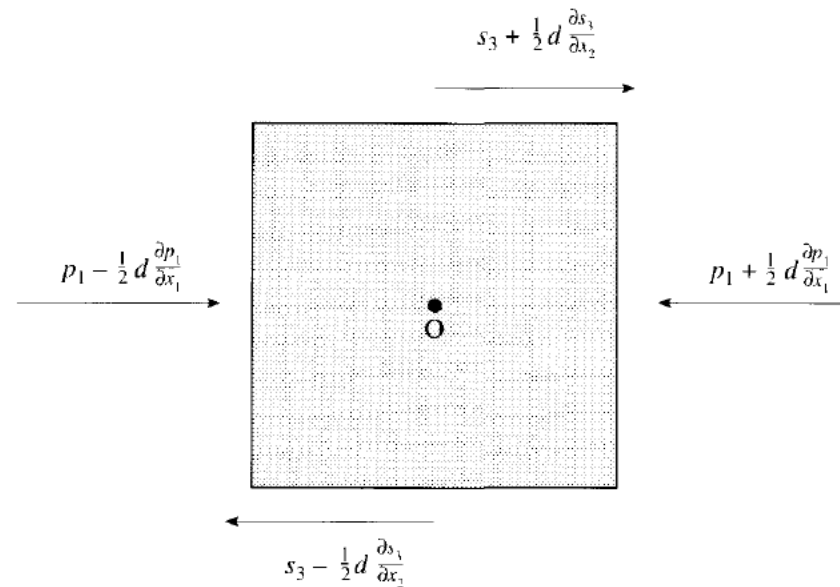

$$f_1 = \frac{1}{\rho} \left(- \frac{\partial p_1}{\partial x_1} + \frac{\partial s_3}{\partial x_2} + \frac{\partial s_2}{\partial x_3} - g \frac{\partial z}{\partial x_1} \right).$$

Supposing the fluid to be Newtonian and effectively incompressible,

$$f_1 = -\frac{\partial}{\partial x_1} \left(\frac{p}{\rho} + gz \right) + \frac{\eta}{\rho} \left(-2 \frac{\partial^2 u_2}{\partial x_1 \partial x_2} - 2 \frac{\partial^2 u_3}{\partial x_1 \partial x_3} + \frac{\partial^2 u_1}{\partial x_2^2} + \frac{\partial^2 u_2}{\partial x_2 \partial x_1} + \frac{\partial^2 u_3}{\partial x_3 \partial x_1} + \frac{\partial^2 u_1}{\partial x_3^2} \right).$$

After rearrangement of terms this becomes

$$f_1 = -\frac{\partial}{\partial x_1} \left(\frac{p}{\rho} + gz \right) - \frac{\eta}{\rho} \left\{ \frac{\partial}{\partial x_2} \left(\frac{\partial u_2}{\partial x_1} - \frac{\partial u_1}{\partial x_2} \right) - \frac{\partial}{\partial x_3} \left(\frac{\partial u_1}{\partial x_3} - \frac{\partial u_3}{\partial x_1} \right) \right\},$$

and the complicated expression enclosed by curly brackets on the right-hand side is just the x_1 component of $\nabla \wedge (\nabla \wedge \mathbf{u})$, i.e. of $\nabla \wedge \boldsymbol{\Omega}$,

The total force in vector form is

$$\mathbf{f} = -\nabla \left(\frac{p}{\rho} + gz \right) - \frac{\eta}{\rho} \nabla \wedge \boldsymbol{\Omega}.$$

Navier-Stokes equation for incompressible fluids

$$-\nabla p^* - \eta \nabla \wedge \boldsymbol{\Omega} = \rho \frac{\partial \mathbf{u}}{\partial t} + \rho (\mathbf{u} \cdot \nabla) \mathbf{u},$$

where p^* is the local *excess mean pressure* defined by (2.21). Equation (6.25) is the equation of motion which replaces Euler's equation for a fluid which has viscosity but which is still effectively incompressible and also, to be on the safe side, isothermal. It differs from Euler's equation only, of course, in so far as it includes a viscous term.

Obviously, the term involving η drops out when $\boldsymbol{\Omega}$ is uniformly equal to zero.

The term involving η also drops out, of course, when $\boldsymbol{\Omega}$ is uniformly equal to some constant other than zero and, more generally still, whenever $\boldsymbol{\Omega}$, although non-uniform, is expressible as the gradient of some scalar potential

Boundary conditions

- The most-used boundary condition is the **no-slip condition**, which states that for a fluid in contact with a solid wall, the velocity of the fluid must equal that of the wall,

No-slip boundary condition:

$$\vec{V}_{\text{fluid}} = \vec{V}_{\text{wall}}$$

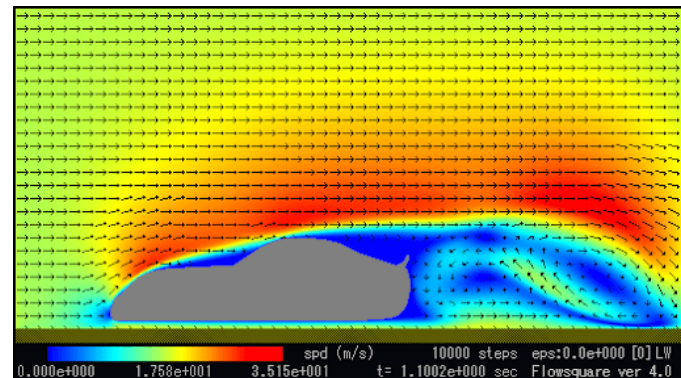
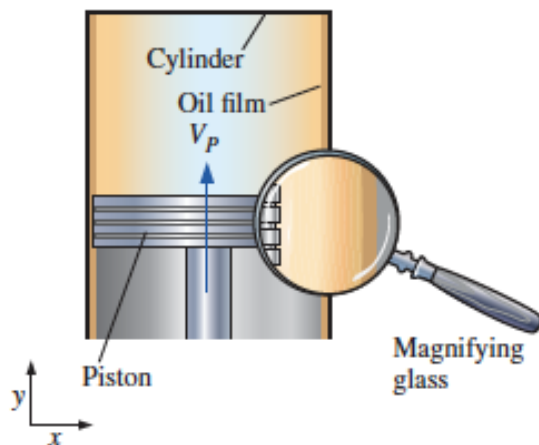

Boundary conditions

- When two fluids (fluid A and fluid B) meet at an interface, the **interface boundary conditions** are

Interface boundary conditions: $\vec{V}_A = \vec{V}_B$ and $\tau_{s,A} = \tau_{s,B}$

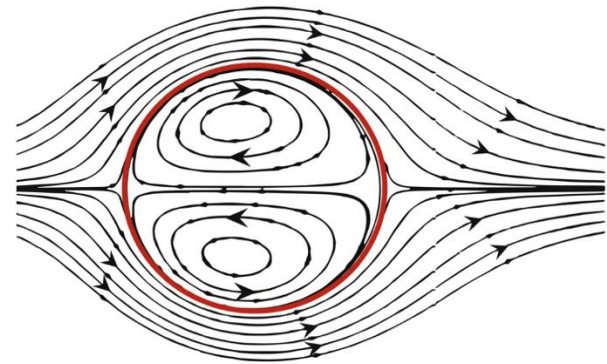
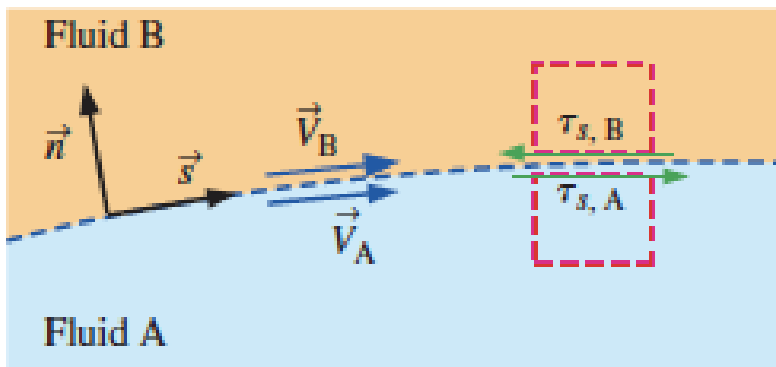

Boundary conditions

- For a liquid in contact with a gas, with negligible surface tension effects, the **free-surface boundary conditions** are

Free-surface boundary conditions: $P_{\text{liquid}} = P_{\text{gas}}$ and $\tau_{s, \text{liquid}} \cong 0$

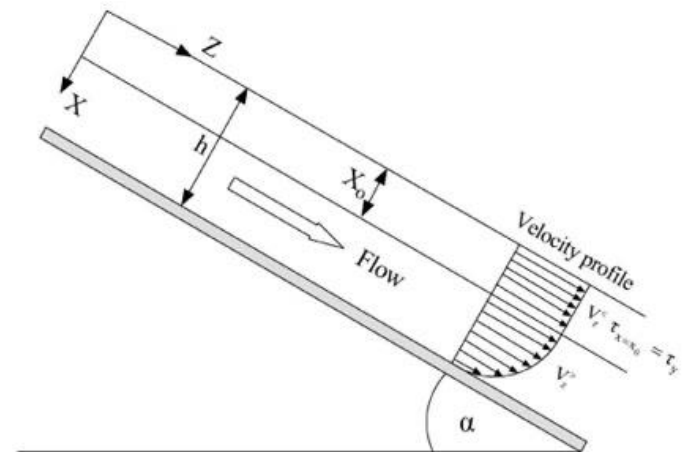
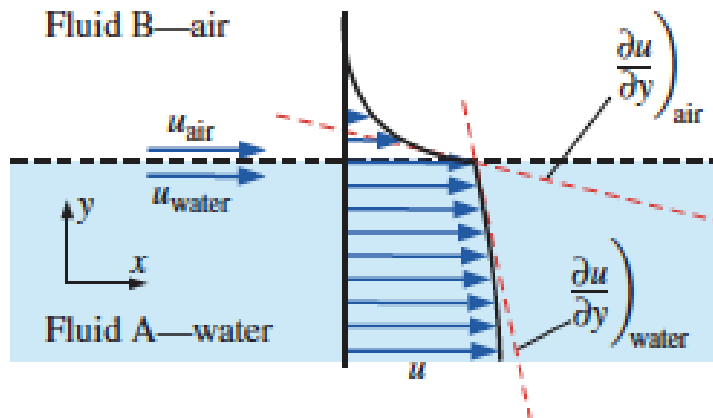

Fully developed Couette flow

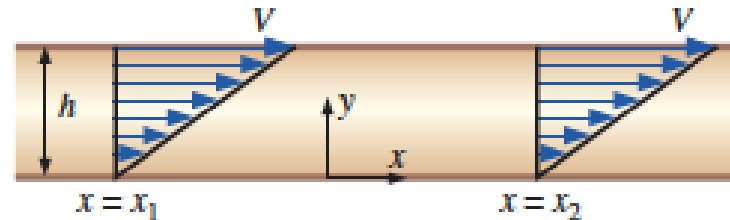
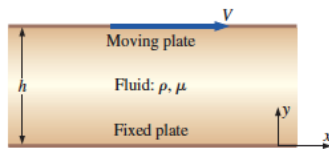

- Consider steady, incompressible, laminar flow of a Newtonian fluid in the narrow gap between two infinite parallel plates. The top plate is moving at speed V , and the bottom plate is stationary. The distance between these two plates is h , and gravity acts in the negative z -direction (into the page).
- The boundary conditions come from imposing the **no-slip condition**: (1) At the bottom plate ($y = 0$), $u = v = w = 0$. (2) At the top plate ($y = h$), $u = V$, $v = 0$, and $w = 0$.
- Continuity

$$\frac{\partial u}{\partial x} + \frac{\partial v}{\partial y} + \frac{\partial w}{\partial z} = 0 \rightarrow \frac{\partial u}{\partial x} = 0$$

Result of continuity:

$$u = u(y) \text{ only}$$

Navier-Stokes x , y and z components:

There is no applied pressure gradient pushing the flow in the x -direction; the flow establishes itself due to viscous stresses caused by the moving upper plate.

$$\cancel{\frac{\partial \vec{u}}{\partial t}} + \underbrace{\vec{u} \cdot \nabla \vec{u}}_{=0} = -\frac{\nabla P}{\rho} + \vec{g} + \eta \nabla^2 \vec{u}$$

In the x direction:

$$\rho \left(\frac{\partial u}{\partial t} + \underbrace{u \frac{\partial u}{\partial x}}_{\neq 0} + \underbrace{v \frac{\partial u}{\partial y}}_{=0} + \underbrace{w \frac{\partial u}{\partial z}}_{=0} \right) = -\frac{\partial P}{\partial x} + \underbrace{\rho g_x}$$

In the y direction:

$$+ \mu \left(\frac{\partial^2 u}{\partial x^2} + \frac{\partial^2 u}{\partial y^2} + \frac{\partial^2 u}{\partial z^2} \right) \rightarrow \frac{d^2 u}{dy^2} = 0$$

$$\frac{\partial P}{\partial y} = 0$$

$= 0$, pois $\frac{\partial u}{\partial x} = 0$

Result of y -momentum:

$$P = P(z) \text{ only}$$

In the z direction:

$$\frac{\partial P}{\partial z} = -\rho g \rightarrow \frac{dP}{dz} = -\rho g$$

Velocity field

$$u = C_1 y + C_2$$

$$\frac{d^2 u}{dy^2} = 0 \quad \nearrow$$

$$u(y=h) = V \Rightarrow C_1 = \frac{V}{h}$$
$$u(y=0) = 0 \Rightarrow C_2 = 0$$

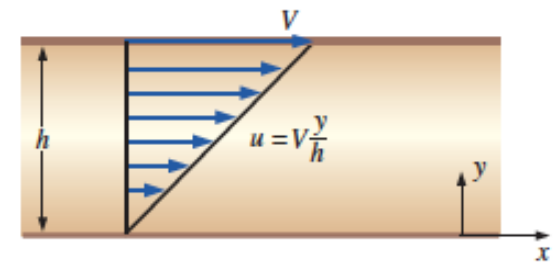

Final result for velocity field:

$$u = V \frac{y}{h}$$

Pressure field

$$P = -\rho g z + C_3$$

Final solution for pressure field:

$$P = P_0 - \rho g z$$

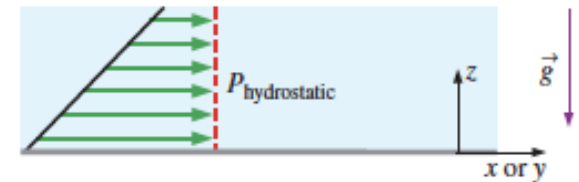

For incompressible flow fields without free surfaces, hydrostatic pressure does not contribute to the dynamics of the flow field.

Shear force on the bottom plate

Deviatoric shear stress tensor

$$\tau_{ij} = \begin{pmatrix} 2\mu \frac{\partial u}{\partial x} & \mu \left(\frac{\partial u}{\partial y} + \frac{\partial v}{\partial x} \right) & \mu \left(\frac{\partial u}{\partial z} + \frac{\partial w}{\partial x} \right) \\ \mu \left(\frac{\partial v}{\partial x} + \frac{\partial u}{\partial y} \right) & 2\mu \frac{\partial v}{\partial y} & \mu \left(\frac{\partial v}{\partial z} + \frac{\partial w}{\partial y} \right) \\ \mu \left(\frac{\partial w}{\partial x} + \frac{\partial u}{\partial z} \right) & \mu \left(\frac{\partial w}{\partial y} + \frac{\partial v}{\partial z} \right) & 2\mu \frac{\partial w}{\partial z} \end{pmatrix} = \begin{pmatrix} 0 & \mu \frac{V}{h} & 0 \\ \mu \frac{V}{h} & 0 & 0 \\ 0 & 0 & 0 \end{pmatrix}$$

Shear force per unit area acting on the wall:

$$\frac{\vec{F}}{A} = \mu \frac{V}{h} \vec{i}$$

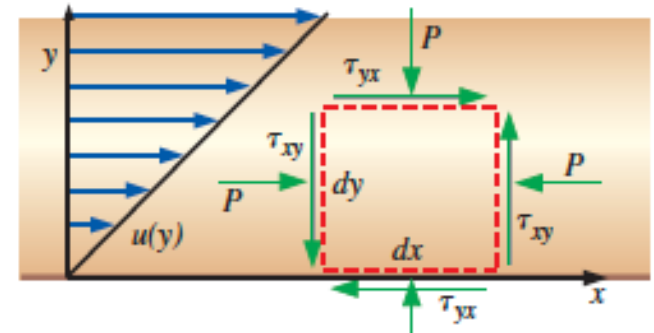

Rotational flow

Discussion The z-component of the linear momentum equation is uncoupled from the rest of the equations; this explains why we get a hydrostatic pressure distribution in the z-direction, even though the fluid is not static, but moving.

The viscous stress tensor is constant everywhere in the flow field, not just at the bottom wall (note that the components of the tensor are not a function of location).

Rotational viscometer

The gap between the two cylinders is very small and contains the fluid.

The magnified region is nearly identical to the parallel plates setup since the gap is small, i.e. $(R_o - R_i) \ll R_o$.

In a viscosity measurement, the angular velocity of the inner cylinder, ω , is measured, as is the applied torque, T_{applied} , required to rotate the cylinder.

From the previous example, we know that the viscous shear stress acting on a fluid element adjacent to the inner cylinder is approximately equal to

$$\tau = \tau_{yx} \cong \mu \frac{V}{\underbrace{R_o - R_i}_h} = \mu \frac{\omega R_i}{R_o - R_i}$$

τ acts to the right on the fluid element adjacent to the inner cylinder wall; hence, the force per unit area acting on the inner cylinder at this location acts to the left with the same magnitude.

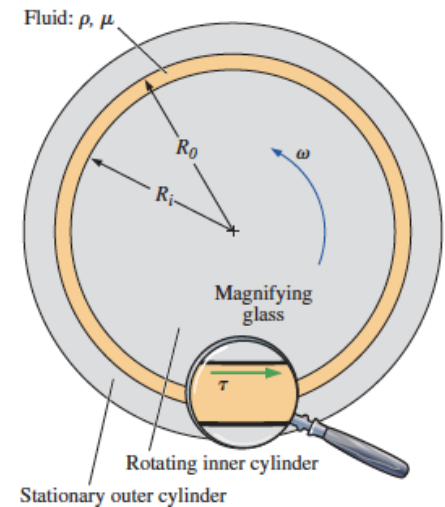

The total clockwise torque acting on the inner cylinder wall due to fluid viscosity is thus equal to this shear stress times the wall area times the moment arm,

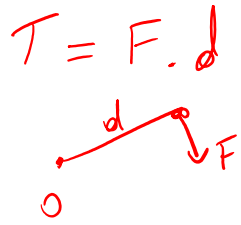

$$T_{\text{viscous}} = \underbrace{\tau A}_{F} R_i \equiv \mu \frac{\omega R_i}{R_o - R_i} (2\pi R_i L) R_i$$

Under steady conditions, the clockwise torque T_{viscous} is balanced by the applied counterclockwise torque T_{applied} . Equating these we find

Viscosity of the fluid:

$$\mu = T_{\text{applied}} \frac{(R_o - R_i)}{2\pi \omega R_i^3 L}$$

}
}
 conhecido medido

Couette flow with applied pressure gradient

The same as in the Couette flow of the previous slides but the x-component of the momentum equation is now:

$$\text{Result of } x\text{-momentum:} \quad \frac{d^2u}{dy^2} = \frac{1}{\mu} \frac{\partial P}{\partial x}$$

Integrating twice yields

$$\text{Integration of } x\text{-momentum:} \quad u = \frac{1}{2\mu} \frac{\partial P}{\partial x} y^2 + C_1 y + C_2$$

For the pressure

$$\text{Integration of } z\text{-momentum:} \quad P = -\rho g z + f(x)$$

$$\text{Final result for pressure field:} \quad P = P_0 + \frac{\partial P}{\partial x} x - \rho g z$$

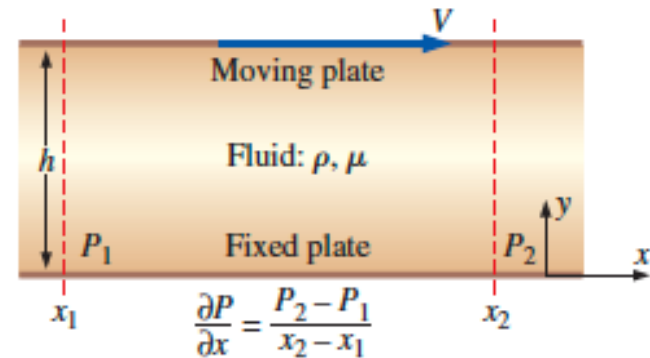

- Applying the velocity boundary conditions

$$u = \frac{1}{2\mu} \frac{\partial P}{\partial x} \times 0 + C_1 \times 0 + C_2 = 0 \rightarrow C_2 = 0$$

$$u = \frac{1}{2\mu} \frac{\partial P}{\partial x} h^2 + C_1 \times h + 0 = V \rightarrow C_1 = \frac{V}{h} - \frac{1}{2\mu} \frac{\partial P}{\partial x} h$$

$$u = \frac{Vy}{h} + \frac{1}{2\mu} \frac{\partial P}{\partial x} (y^2 - hy)$$

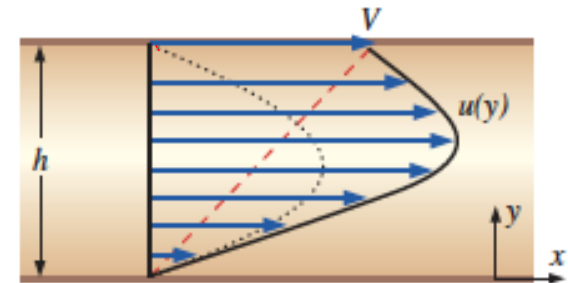

- $u(y)$ is the velocity profile of Couette flow between parallel plates with an applied negative pressure gradient; the dashed red line indicates the profile for a zero pressure gradient, and the dotted line indicates the profile for a negative pressure gradient with the upper plate stationary ($V < 0$).

Dimensional analysis

- The problem is set in terms of velocity u as a function of y , h , V , μ , and $-P/-x$. There are six variables (including the dependent variable u), and since there are three primary dimensions (mass, length, and time), we expect $6 - 3$ dimensionless groups. When we pick h , V , and μ as our repeating variables, we get the following result:

$$\text{Result of dimensional analysis: } \frac{u}{V} = f\left(\frac{y}{h}, \frac{h^2}{\mu V} \frac{\partial P}{\partial x}\right)$$

$$\text{Dimensionless form of velocity field: } u^* = y^* + \frac{1}{2} P^* y^* (y^* - 1)$$

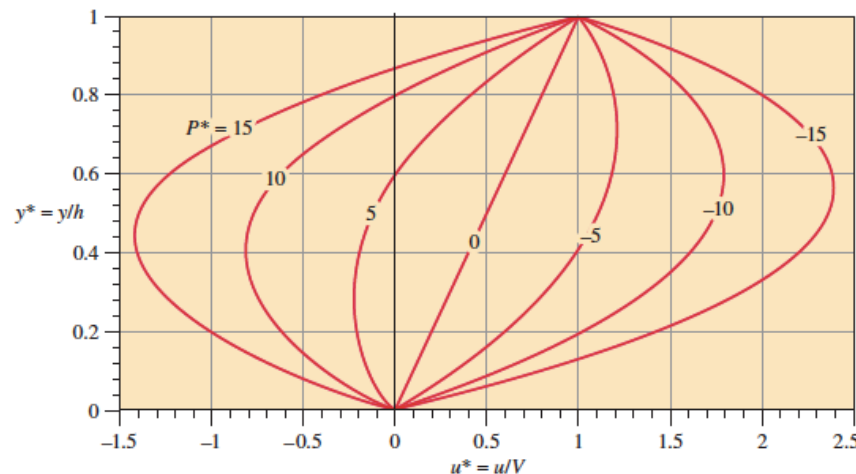

Oil film falling down a vertical wall

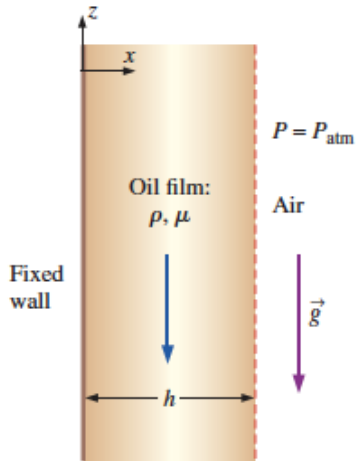

1. The wall is infinite in the yz -plane (y is into the page for a right-handed coordinate system).
2. The flow is steady (all partial derivatives with respect to time are zero).
3. The flow is parallel (the x -component of velocity, u , is zero everywhere).
4. The fluid is incompressible and Newtonian with constant properties, and the flow is laminar.
5. Pressure $P = P_{\text{atm}}$ constant at the free surface. In other words, there is no applied pressure gradient pushing the flow; the flow establishes itself due to a balance between gravitational forces and viscous forces. In addition, since there is no gravity force in the horizontal direction, $P = P_{\text{atm}}$ everywhere.
6. The velocity field is purely 2D, which implies that derivatives w.r. to y are zero.
7. Gravity acts in the negative z direction.
8. The boundary conditions are: no slip at the wall; at $x = 0$, $u = v = w = 0$. At the free surface ($x = h$), there is negligible shear, which for a vertical free surface, in this coordinate system, means $\frac{\partial w}{\partial x} = 0$ at $x = h$.

Continuity:

$$\frac{\partial u}{\partial x} + \frac{\partial v}{\partial y} + \frac{\partial w}{\partial z} = 0 \rightarrow \frac{\partial w}{\partial z} = 0$$

Result of continuity:

$$w = w(x) \text{ only}$$

$$\rho \left(\frac{\partial v}{\partial t} + u \frac{\partial v}{\partial x} + v \frac{\partial v}{\partial y} + w \frac{\partial v}{\partial z} \right) = -\frac{\partial p}{\partial z} + \underbrace{\rho g_z}$$

NS w:

$$+ \mu \left(\frac{\partial^2 w}{\partial x^2} + \frac{\partial^2 w}{\partial y^2} + \frac{\partial^2 w}{\partial z^2} \right) \rightarrow \frac{d^2 w}{dx^2} = \frac{\rho g}{\mu}$$

$$w = \frac{\rho g}{2\mu} x^2 + C_1 x + C_2$$

Integration:

Boundary condition (1): $w = 0 + 0 + C_2 = 0 \quad C_2 = 0$

and

Boundary condition (2): $\left. \frac{dw}{dx} \right|_{x=h} = \frac{\rho g}{\mu} h + C_1 = 0 \rightarrow C_1 = -\frac{\rho g h}{\mu}$

Velocity field: $w = \frac{\rho g}{2\mu} x^2 - \frac{\rho g}{\mu} h x = \frac{\rho g x}{2\mu} (x - 2h)$

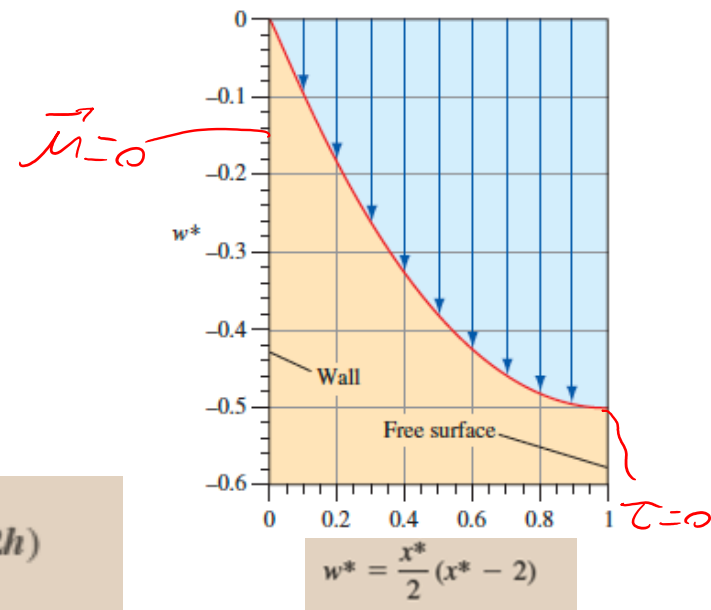

Flow in a round pipe: Poiseuille

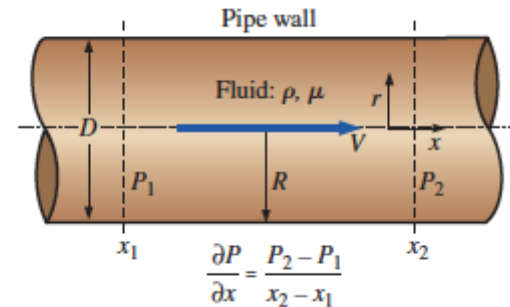

- 1 The pipe is infinitely long in the x -direction.
- 2 The flow is steady (all partial time derivatives are zero).
- 3 This is a parallel flow (**the r -component of velocity, u_r , is zero**).
- 4 The fluid is incompressible and Newtonian with constant properties, and the flow is laminar.
- 5 A **constant pressure gradient** is applied in the x -direction such that pressure changes linearly with respect to x .
- 6 The velocity field is axisymmetric with no swirl, implying **that $u_\theta = 0$ and all partial derivatives with respect to θ are zero**.
- 7 We ignore the effects of **gravity**.
- 8 The first boundary condition comes from imposing the no slip condition at the pipe wall: (1) at $r = R, \vec{V} = 0$.
- 9 The second boundary condition comes from the fact that the centerline of the pipe is an axis of symmetry: (2) at $r = 0, \frac{\partial u}{\partial r} = 0$. Alternatively: the velocity is finite at the center.

N-S

$$\frac{\partial \vec{u}}{\partial t} + \vec{u} \cdot \nabla \vec{u} = -\frac{\nabla p}{\rho} + \vec{g} + \nu \nabla^2 \vec{u}$$

Recall – Cylindrical coordinates

Gradient $\frac{\partial f}{\partial \rho} \hat{\rho} + \frac{1}{\rho} \frac{\partial f}{\partial \varphi} \hat{\varphi} + \frac{\partial f}{\partial z} \hat{z}$

Divergent $\frac{1}{\rho} \frac{\partial (\rho A_\rho)}{\partial \rho} + \frac{1}{\rho} \frac{\partial A_\varphi}{\partial \varphi} + \frac{\partial A_z}{\partial z}$

Laplacian $\frac{1}{\rho} \frac{\partial}{\partial \rho} \left(\rho \frac{\partial f}{\partial \rho} \right) + \frac{1}{\rho^2} \frac{\partial^2 f}{\partial \varphi^2} + \frac{\partial^2 f}{\partial z^2}$

https://en.wikipedia.org/wiki/Del_in_cylindrical_and_spherical_coordinates

Continuity:

$$\frac{1}{r} \frac{\partial(r u_r)}{\partial r} + \frac{1}{r} \frac{\partial(u_\theta)}{\partial \theta} + \frac{\partial u}{\partial x} = 0 \quad \rightarrow \quad \frac{\partial u}{\partial x} = 0$$

Result of continuity: $u = u(r)$ only

NS u:

$$\rho \left(\frac{\partial u}{\partial t} + u_r \frac{\partial u}{\partial r} + \frac{u_\theta}{r} \frac{\partial u}{\partial \theta} + u \frac{\partial u}{\partial x} \right)$$

$$= -\frac{\partial P}{\partial x} + \underbrace{\rho g_x}_{\text{gravity}} + \mu \left(\frac{1}{r} \frac{\partial}{\partial r} \left(r \frac{\partial u}{\partial r} \right) + \frac{1}{r^2} \frac{\partial^2 u}{\partial \theta^2} + \frac{\partial^2 u}{\partial x^2} \right)$$

$$\frac{1}{r} \frac{d}{dr} \left(r \frac{du}{dr} \right) = \frac{1}{\mu} \frac{\partial P}{\partial x}$$

r-momentum: $\frac{\partial P}{\partial r} = 0$

NS p:

Result of *r*-momentum: $P = P(x)$ only

Integration of NS for *u*:

$$r \frac{du}{dr} = \frac{r^2}{2\mu} \frac{dP}{dx} + C_1$$

$$u = \frac{r^2}{4\mu} \frac{dP}{dx} + C_1 \ln r + C_2$$

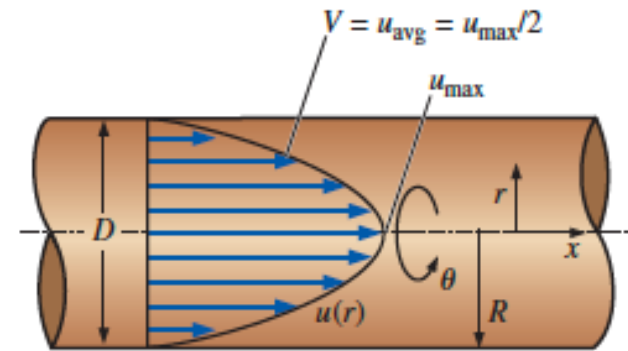

Axial velocity: $u = \frac{1}{4\mu} \frac{dP}{dx} (r^2 - R^2)$

Poiseuille's law for the flow rate

Maximum axial velocity: $u_{\max} = -\frac{R^2}{4\mu} \frac{dP}{dx}$

$$\dot{V} = \int_{\theta=0}^{2\pi} \int_{r=0}^R ur \, dr \, d\theta = \frac{2\pi}{4\mu} \frac{dP}{dx} \int_{r=0}^R (r^2 - R^2)r \, dr = -\frac{\pi R^4}{8\mu} \frac{dP}{dx}$$

Average axial velocity: $V = \frac{\dot{V}}{A} = \frac{(-\pi R^4/8\mu) (dP/dx)}{\pi R^2} = -\frac{R^2}{8\mu} \frac{dP}{dx}$

Viscous shear force

The stress tensor is

$$\tau_{ij} = \begin{pmatrix} \tau_{rr} & \tau_{r\theta} & \tau_{rx} \\ \tau_{\theta r} & \tau_{\theta\theta} & \tau_{\theta x} \\ \tau_{xr} & \tau_{x\theta} & \tau_{xx} \end{pmatrix} = \begin{pmatrix} 0 & 0 & \mu \frac{\partial u}{\partial r} \\ 0 & 0 & 0 \\ \mu \frac{\partial u}{\partial r} & 0 & 0 \end{pmatrix}$$

Viscous shear stress at the pipe wall: $\tau_{rx} = \mu \frac{du}{dr} = \frac{R}{2} \frac{dP}{dx}$

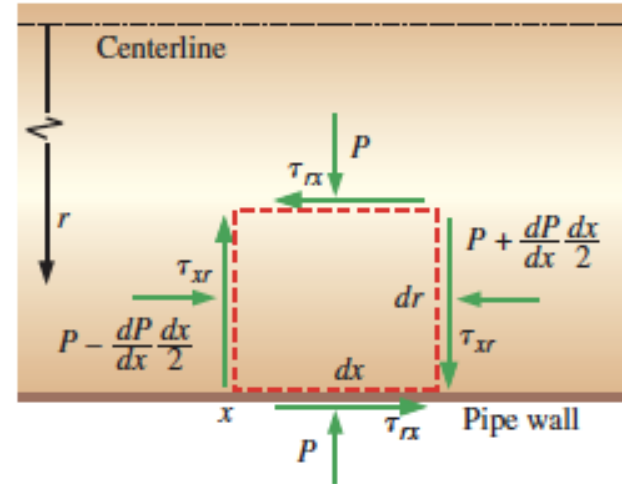

For flow from left to right, dP/dx is negative, so the viscous shear stress on the bottom of the fluid element at the wall is in the direction opposite to that indicated in the figure. (This agrees with our intuition since the pipe wall exerts a retarding force on the fluid.) The shear force per unit area on the wall is equal and opposite to this; hence,

Viscous shear force per unit area acting on the wall: $\frac{\vec{F}}{A} = -\frac{R}{2} \frac{dP}{dx} \vec{i}$

Viscosity and Poiseuille's Law:

https://www.youtube.com/watch?v=wTnl_kfPBhQ

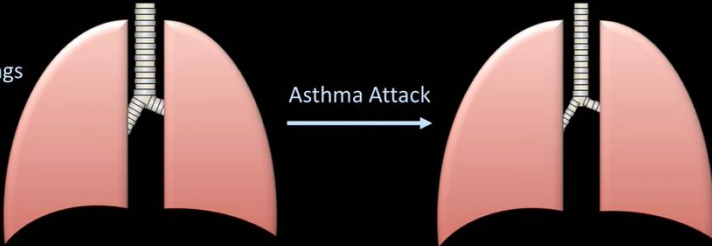

Lungs

Asthma Attack

If airway radius reduced by 25%, by how much is airway resistance affected?

$$\frac{R_{\text{attack}}}{R_{\text{baseline}}} = \frac{\frac{8 \cdot \mu \cdot L}{\pi r_{\text{attack}}^4}}{\frac{8 \cdot \mu \cdot L}{\pi r_{\text{baseline}}^4}} = \frac{1}{\left(\frac{3}{4} r_{\text{baseline}}\right)^4} \approx 3.2$$

Airway resistance > 300% baseline!

Full screen (f)

6:53 / 9:27

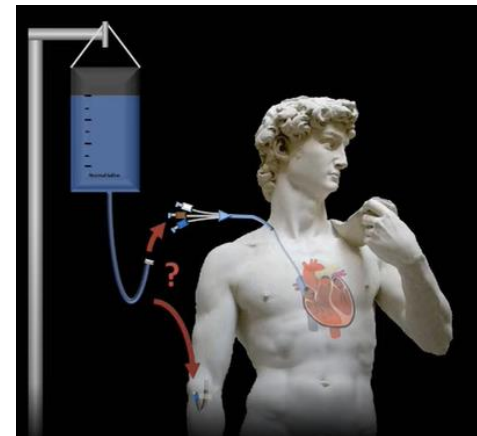

Force balance

Navier-Stokes equation

$$\frac{\partial \vec{u}}{\partial t} + \vec{u} \cdot \nabla \vec{u} = -\frac{\nabla p}{\rho} + \vec{g} + \nu \nabla^2 \vec{u}$$

In most of the previous examples, the acceleration of the fluid elements is zero. It means that the viscous force balance the external force (e.g., gravity) or pressure gradients in such a way that the sum of forces acting on a fluid element is zero.

Alternative derivation for flow in a circular pipe

Obtain the momentum equation by applying a momentum balance to a differential volume element, and we obtain the velocity profile by solving it.

Free-body diagram of a **ring-shaped differential fluid element** of radius r , thickness dr , and length dx oriented coaxially with a horizontal pipe in fully developed laminar flow.

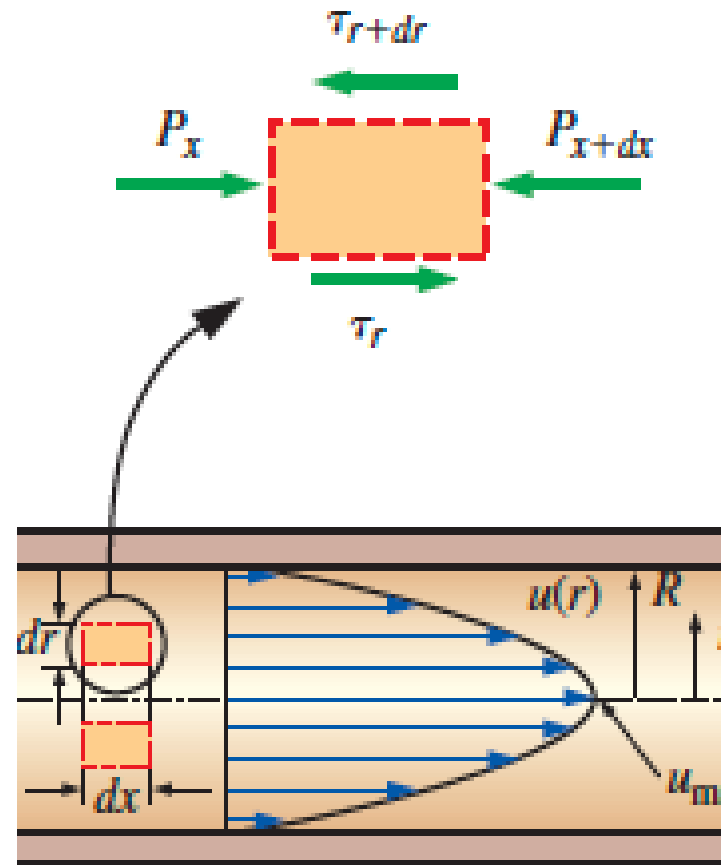

In fully developed laminar flow the axial velocity is, $u = u(r)$. There is no motion in the radial direction. There is no acceleration (check: calculate the acceleration and verify that it is zero).

$$\Sigma \vec{F} = 0$$

- Consider a ring-shaped differential volume element of radius r , thickness dr , and length dx oriented coaxially with the pipe.
- The volume element involves only pressure and viscous effects and thus the pressure and shear forces must balance each other. The pressure force acting on a submerged plane surface is the product of the pressure at the centroid of the surface and the surface area. A force balance on the volume element in the flow direction (x) gives

$$\begin{aligned}
 & \underbrace{(2\pi r dr P)}_{dA} \textcircled{1} \Big|_x - (2\pi r dr P) \Big|_{x+dx} \textcircled{2} - \\
 & - (2\pi r dx \tau) \Big|_r \textcircled{3} + (2\pi r dx \tau) \Big|_{r+dr} \textcircled{4} = 0
 \end{aligned}$$

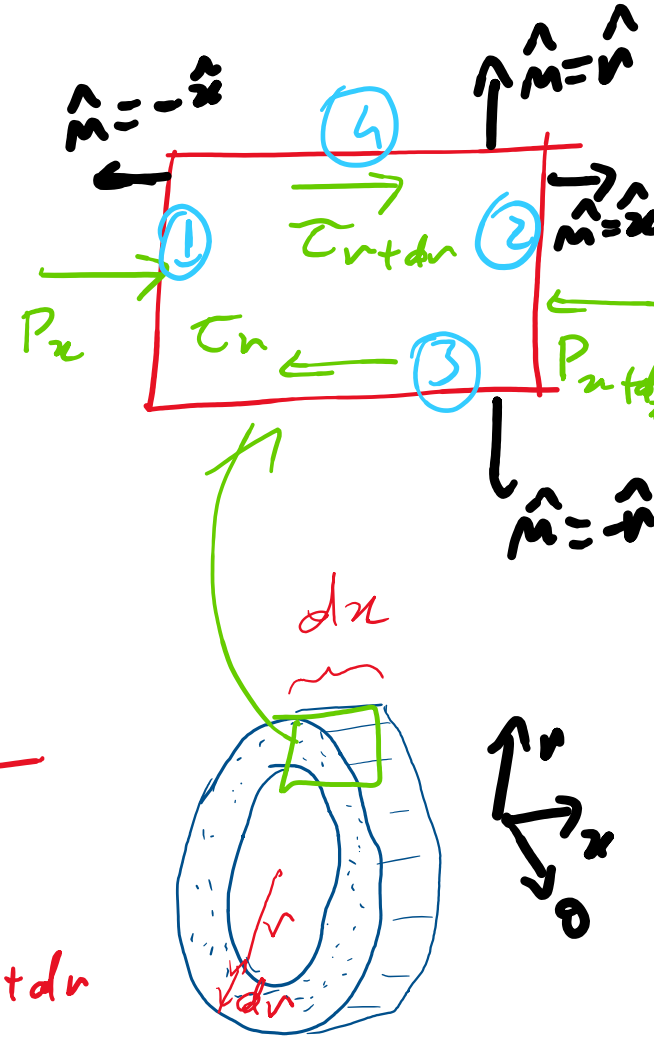

$$(\dots) \div 2\pi x \, dx \, dr$$

$$\frac{(rP)_x - (rP)_{x+dx}}{dx} + \frac{-(r\tau)_r + (r\tau)_{r+dr}}{dr} = 0$$

$$r \frac{P_{x+dx} - P_x}{dx} - \frac{(r\tau)_{r+dr} - (r\tau)_r}{dr} = 0$$

$$r \frac{dP}{dx} - \frac{d}{dr}(r\tau) = 0, \quad \text{m.s.s} \quad \tau_{rx} = \mu \frac{du_x}{dr}$$

$$r \frac{dP}{dx} = \mu \frac{d}{dr} \left(r \frac{du_x}{dr} \right)$$

Same equation obtained with NS:

$$\frac{1}{r} \frac{d}{dr} \left(r \frac{du}{dr} \right) = \frac{1}{\mu} \frac{\partial P}{\partial x}$$

Recall

Deviatoric stress tensor

$$\tau_{ij} = \begin{pmatrix} \tau_{rr} & \tau_{r\theta} & \tau_{rz} \\ \tau_{\theta r} & \tau_{\theta\theta} & \tau_{\theta z} \\ \tau_{zr} & \tau_{z\theta} & \tau_{zz} \end{pmatrix}$$
$$= \begin{pmatrix} 2\mu \frac{\partial u_r}{\partial r} & \mu \left[r \frac{\partial}{\partial r} \left(\frac{u_\theta}{r} \right) + \frac{1}{r} \frac{\partial u_r}{\partial \theta} \right] & \mu \left(\frac{\partial u_r}{\partial z} + \frac{\partial u_z}{\partial r} \right) \\ \mu \left[r \frac{\partial}{\partial r} \left(\frac{u_\theta}{r} \right) + \frac{1}{r} \frac{\partial u_r}{\partial \theta} \right] & 2\mu \left(\frac{1}{r} \frac{\partial u_\theta}{\partial \theta} + \frac{u_r}{r} \right) & \mu \left(\frac{\partial u_\theta}{\partial z} + \frac{1}{r} \frac{\partial u_z}{\partial \theta} \right) \\ \mu \left(\frac{\partial u_r}{\partial z} + \frac{\partial u_z}{\partial r} \right) & \mu \left(\frac{\partial u_\theta}{\partial z} + \frac{1}{r} \frac{\partial u_z}{\partial \theta} \right) & 2\mu \frac{\partial u_z}{\partial z} \end{pmatrix}$$

Stress tensor

$$\sigma_{ij} = -P \delta_{ij} + \tau_{ij}$$

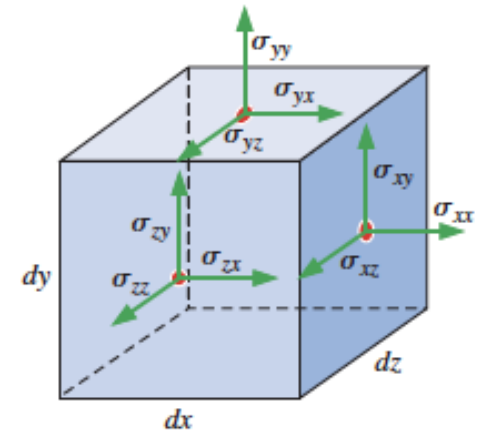

Different fluid element (r from 0 to R)

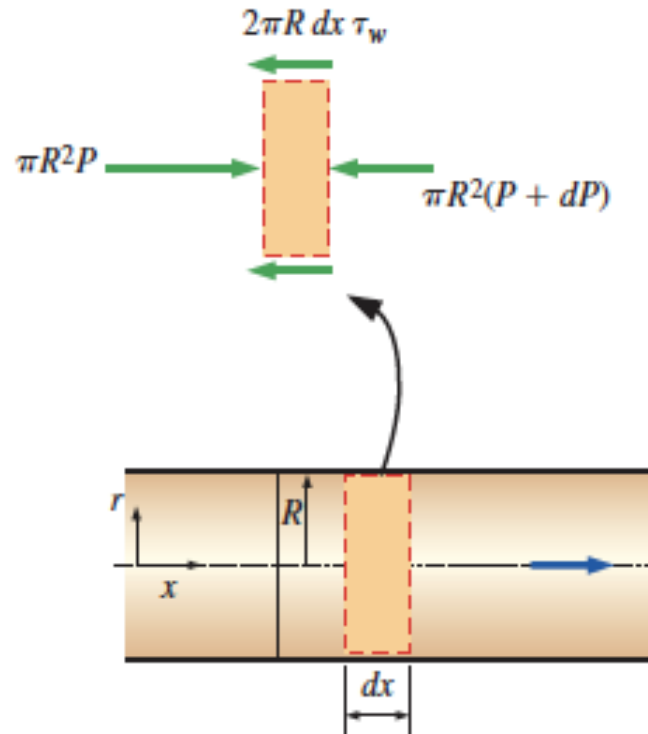

Force balance:

$$\pi R^2 P - \pi R^2 (P + dP) - 2\pi R dx \tau_w = 0$$

Simplifying:

$$\frac{dP}{dx} = -\frac{2\tau_w}{R}$$

Separation of variables implies that the **pressure gradient is constant** $\frac{dP}{dx} = -\frac{2\tau_w}{R}$

The velocity profile is obtained by integration and use of the boundary conditions:

$$u(r) = \frac{r^2}{4\mu} \left(\frac{dP}{dx} \right) + C_1 \ln r + C_2$$

\uparrow $u(r=R) = 0$
 \downarrow $= 0$ ($u(r=0)$ e' finito)

$$u(r) = -\frac{R^2}{4\mu} \left(\frac{dP}{dx} \right) \left(1 - \frac{r^2}{R^2} \right)$$

The average velocity is

$$V_{\text{avg}} = \frac{2}{R^2} \int_0^R u(r)r \, dr = \frac{-2}{R^2} \int_0^R \frac{R^2}{4\mu} \left(\frac{dP}{dx} \right) \left(1 - \frac{r^2}{R^2} \right) r \, dr = -\frac{R^2}{8\mu} \left(\frac{dP}{dx} \right)$$

In terms of which the profile becomes

$$u(r) = 2V_{\text{avg}} \left(1 - \frac{r^2}{R^2} \right)$$

$r=0 \Rightarrow u(r) = u_{\text{max}} = 2V_{\text{avg}}$

Effect of gravity

- Gravity has no effect on flow in horizontal pipes, but it has a significant effect on both the velocity and the flow rate in uphill or downhill pipes.
- Relations for inclined pipes can be obtained in a similar manner from a force balance in the direction of flow. The only additional force in this case is the component of the fluid weight in the flow direction, which is

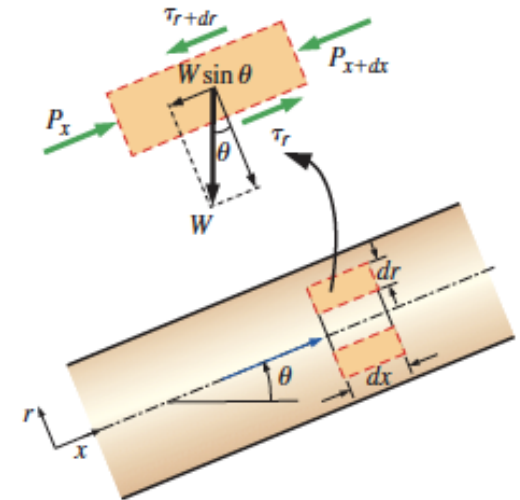

$$W_x = W \sin \theta = \rho g V_{\text{element}} \sin \theta = \rho g (2\pi r dr dx) \sin \theta$$

Then

$$(2\pi r dr P)_x - (2\pi r dr P)_{x+dx} + (2\pi r dx \tau)_r - (2\pi r dx \tau)_{r+dr} - \rho g (2\pi r dr dx) \sin \theta = 0$$

$\leftarrow \frac{D\vec{u}}{Dt} = 0$
 force volumetrica

and

$$\frac{\mu}{r} \frac{d}{dr} \left(r \frac{du}{dr} \right) = \frac{dP}{dx} + \rho g \sin \theta$$

Effect of gravity

The velocity profile, average velocity and flow rate are:

$$u(r) = -\frac{R^2}{4\mu} \left(\frac{dP}{dx} + \rho g \sin \theta \right) \left(1 - \frac{r^2}{R^2} \right)$$

$$V_{\text{avg}} = \frac{(\Delta P - \rho g L \sin \theta) D^2}{32\mu L} \quad \text{and} \quad \dot{V} = \frac{(\Delta P - \rho g L \sin \theta) \pi D^4}{128\mu L}$$

- As expected, gravity opposes uphill flow, enhances downhill flow, and has no effect on horizontal flow.
- Downhill flow can occur even in the absence of a pressure difference applied by a pump. For the case of $P_1 = P_2$ (i.e., no applied pressure difference), the pressure throughout the entire pipe would remain constant, and the fluid would flow through the pipe under the influence of gravity at a rate that depends on the angle of inclination, reaching its maximum value when the pipe is vertical.

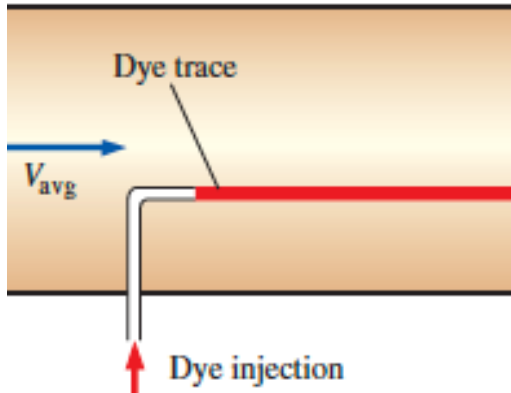

(a) Laminar flow

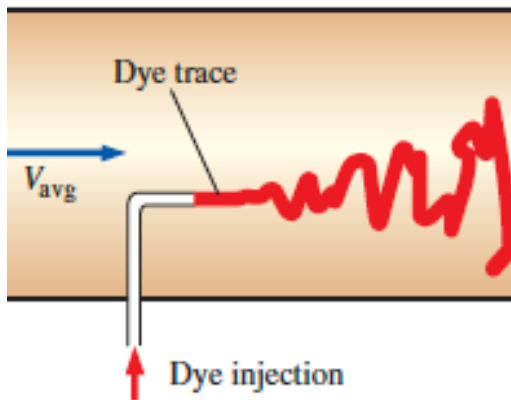

(b) Turbulent flow

The flow regime in the first case is said to be laminar, characterized by smooth streamlines and highly ordered motion, and turbulent in the second case, where it is characterized by velocity fluctuations and highly disordered motion.

The transition from laminar to turbulent flow does not occur suddenly; rather, it occurs over some region in which the flow fluctuates between laminar and turbulent flows before it becomes fully turbulent.

Most flows encountered in practice are turbulent. Laminar flow is encountered when highly viscous fluids such as oils flow in small pipes or narrow passages.

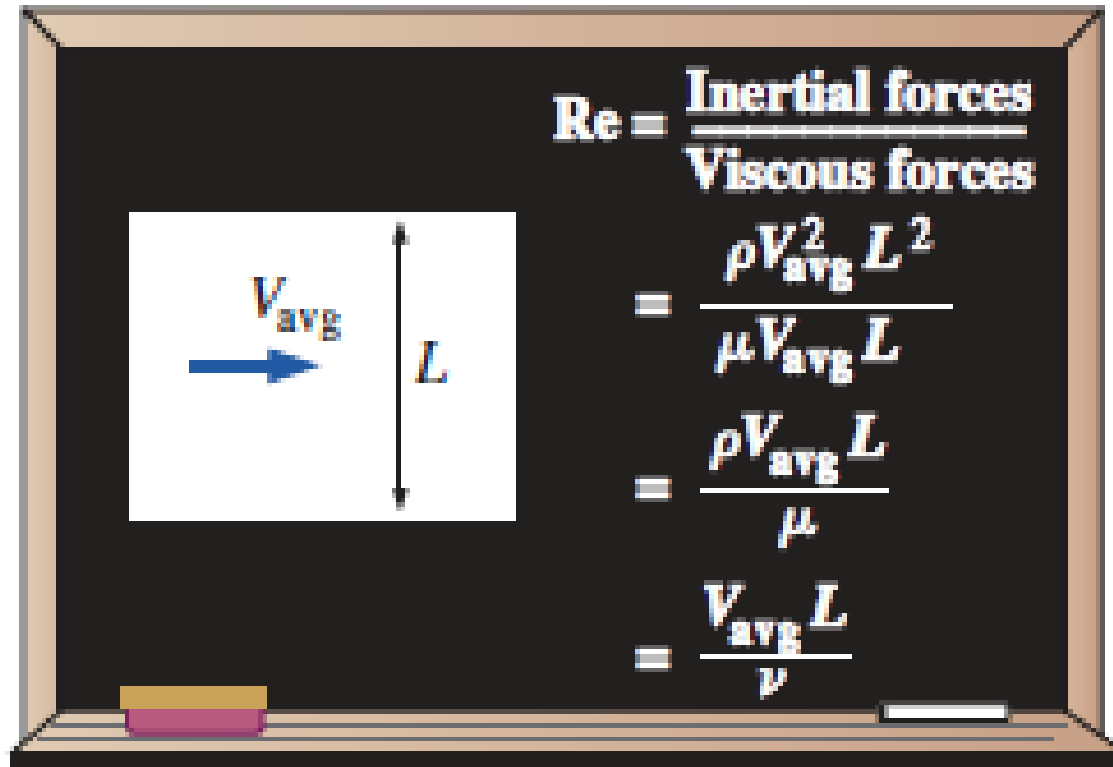

Reynolds
number

$Re \lesssim 2300$ laminar flow

$2300 \lesssim Re \lesssim 4000$ transitional flow

$Re \gtrsim 4000$ turbulent flow

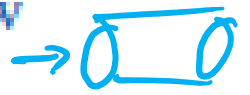
↑ Para o escoamento de Poiseuille → 

https://www.youtube.com/watch?v=6A8B05V4OzA



flow turbulence tube

Flow Velocity Increasing 

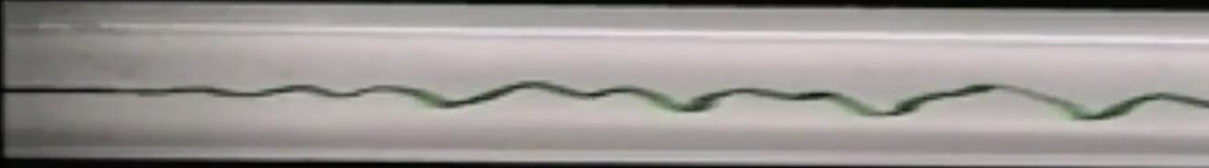
Dye Injection -> 

Transitional Flow (Wavy)
Reynolds number $Re \sim 2,200-4,000$



#fluidmechanics #fluiddynamics

Visualization of Laminar to Turbulent Flow Transition in a Pipe



Fluid Matters
4.72K subscribers

Subscribe

 7 

 Share



Sudden motion of an infinite flat plate

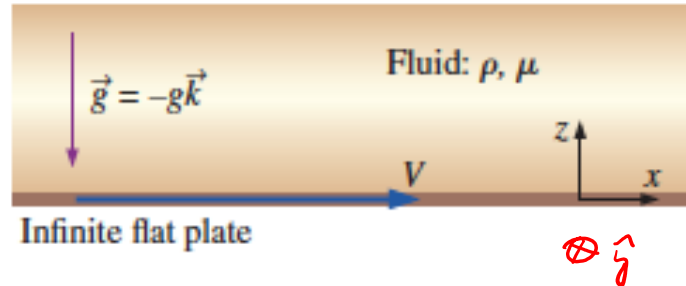

$$\mu_y \neq 0$$

$$\mu_x, \mu_z = 0$$

Consider a Newtonian fluid on top of a flat plate in the xy -plane at $z = 0$. The fluid is at rest until $t = 0$, when the plate suddenly starts moving at speed V in the x -direction.

- 1 The wall is infinite in the x - and y -directions; thus, nothing is special about any particular x - or y -location.
- 2 The flow is parallel everywhere ($w = 0$).
- 3 Pressure $P = \text{constant with respect to } x$. In other words, there is no applied pressure gradient pushing the flow in the x -direction; flow occurs due to viscous stresses caused by the moving plate.
- 4 The fluid is incompressible and Newtonian with constant properties, and the flow is laminar.
- 5 The velocity field is two-dimensional in the xz -plane; therefore, $v = 0$, and **all partial derivatives with respect to y are zero**.
- 6 Gravity acts in the $-z$ -direction

Initial and boundary conditions:

- (1) At $t = 0$, $u = 0$ everywhere (no flow until the plate starts moving);
- (2) at $z = 0$, $u = V$ for all values of x and y (no-slip condition at the plate);
- (3) as $z \rightarrow \infty$, $u \rightarrow 0$ (far from the plate, the effect of the moving plate is not felt);
- (4) at $z = 0$, $P = P_{\text{wall}}$ (the pressure at the wall is constant at any x - or y -location along the plate).

$$\nabla \cdot \vec{u} = 0$$

• Continuity

$$\frac{\partial u}{\partial x} + \overset{u_x=0}{\cancel{\frac{\partial v}{\partial y}}} + \overset{u_z=0}{\cancel{\frac{\partial w}{\partial z}}} = 0 \rightarrow \boxed{\frac{\partial u}{\partial x} = 0}$$

Result of continuity:

$$u = u(z, t) \text{ only}$$

N-S:

$$\frac{\partial \vec{u}}{\partial t} + \vec{u} \cdot \nabla \vec{u} = -\nabla \frac{P}{\rho} + \vec{g} + \nu \nabla^2 \vec{u}$$

• y -momentum

$$\frac{\partial P}{\partial y} = 0$$

Result of y -momentum:

$$P = P(z, t) \text{ only}$$

z - momentum

$$\frac{\partial P}{\partial z} = -\rho g$$

$$\Rightarrow P = P_{wall} - \rho g z$$

x - momentum

Nota: $\vec{\omega} = \frac{D\vec{\omega}}{Dt} \neq 0$ (Não se pode usar balança de forças)

$$\nabla \cdot \vec{u} = 0$$

$$P(z) = C_1 e$$

$$\rho \left(\frac{\partial u}{\partial t} + u \frac{\partial u}{\partial x} + v \frac{\partial u}{\partial y} + w \frac{\partial u}{\partial z} \right) = -\frac{\partial P}{\partial x} + \underbrace{\rho g_x}$$

↑
Não é estacionário

$$+ \mu \left(\frac{\partial^2 u}{\partial x^2} + \frac{\partial^2 u}{\partial y^2} + \frac{\partial^2 u}{\partial z^2} \right) \rightarrow \rho \frac{\partial u}{\partial t} = \mu \frac{\partial^2 u}{\partial z^2}$$

$$\nabla \cdot \vec{u} = 0$$

$$\frac{\partial}{\partial y} (\dots) = 0$$

$$\nu \cdot \rho$$

(Diffusion equation for u, with D=ν)

na mesma papel que
• coef. de difusão.

Eq. de difusão

$$\frac{\partial c}{\partial t} = D \frac{\partial^2 c}{\partial x^2}$$

Result of x-momentum:

$$\frac{\partial u}{\partial t} = \nu \frac{\partial^2 u}{\partial z^2}$$

- The 1-D diffusion equation is linear
- It is a partial differential equation (PDE)
- It is used in many fields of physics

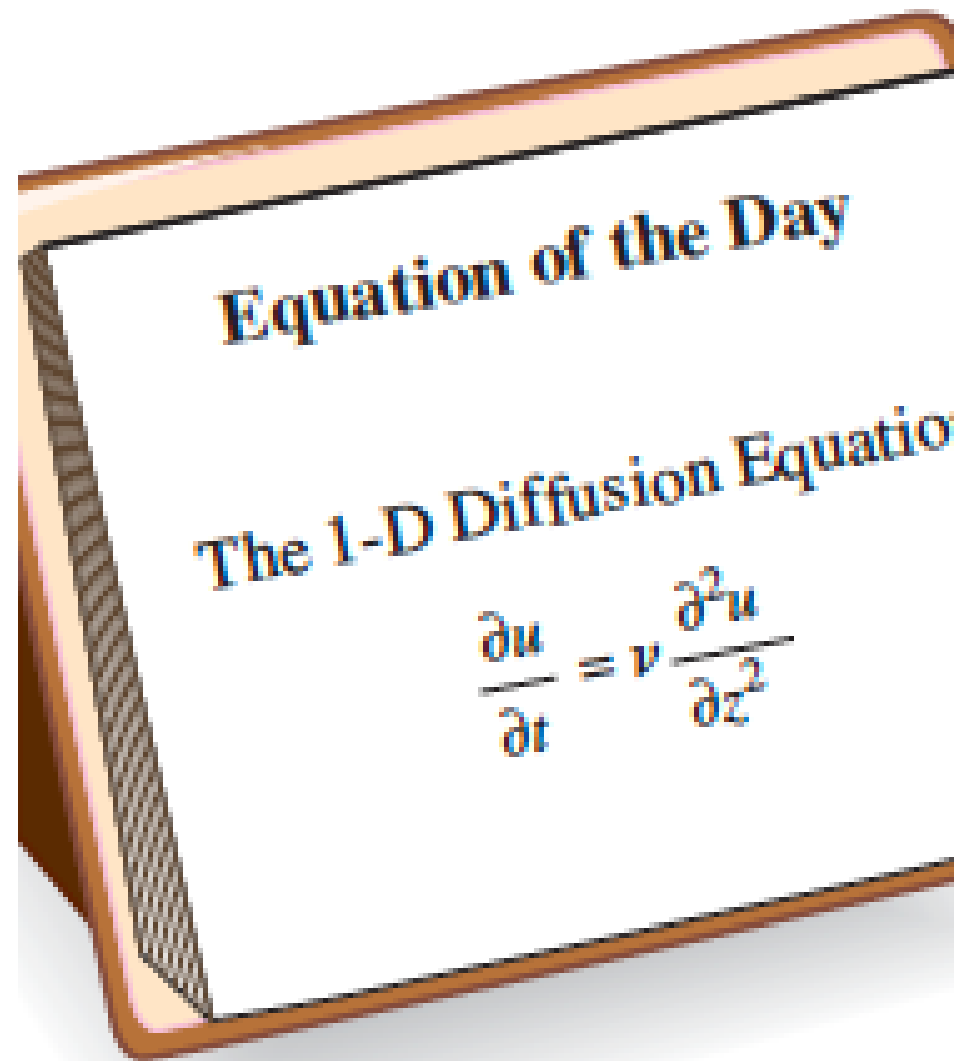

Diffusion equation

DIFFUSION

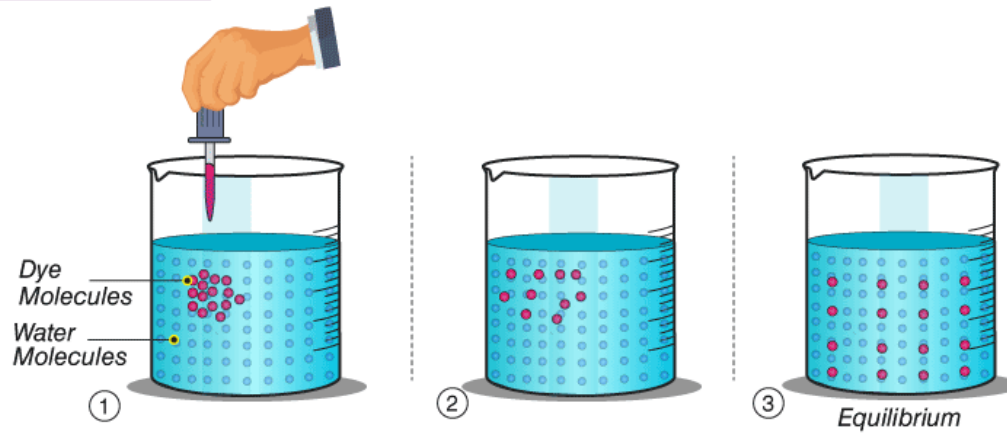

$$\frac{\partial C(x,t)}{\partial t} = D \frac{\partial^2 C(x,t)}{\partial x^2}$$

Coef. de difusão

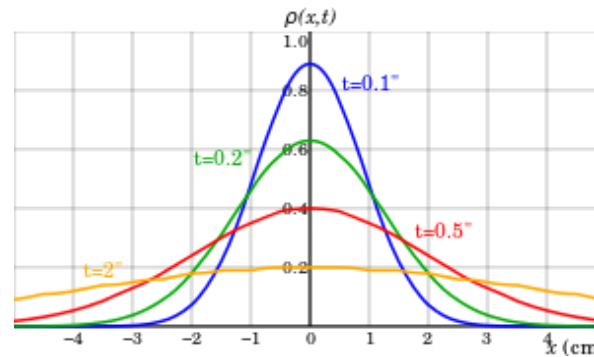

From the z-component we obtain the pressure

$$P = -\rho g z + f(t)$$

Boundary condition (4): $P = 0 + f(t) = P_{\text{wall}} \rightarrow f(t) = P_{\text{wall}}$

Final result for pressure field: $P = P_{\text{wall}} - \rho g z$

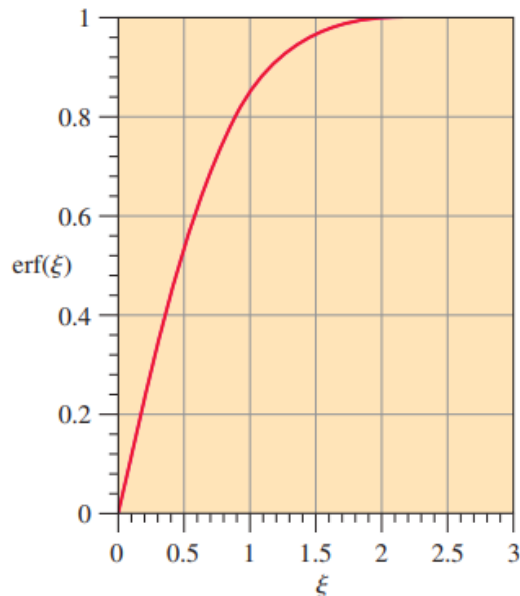

Final result for velocity field: $u = V \left[1 - \operatorname{erf}\left(\frac{z}{2\sqrt{\nu t}}\right) \right]$

Error function: $\operatorname{erf}(\xi) = \frac{2}{\sqrt{\pi}} \int_0^\xi e^{-\eta^2} d\eta$

Verify that this is a solution of the differential equation and that it satisfies the boundary conditions.

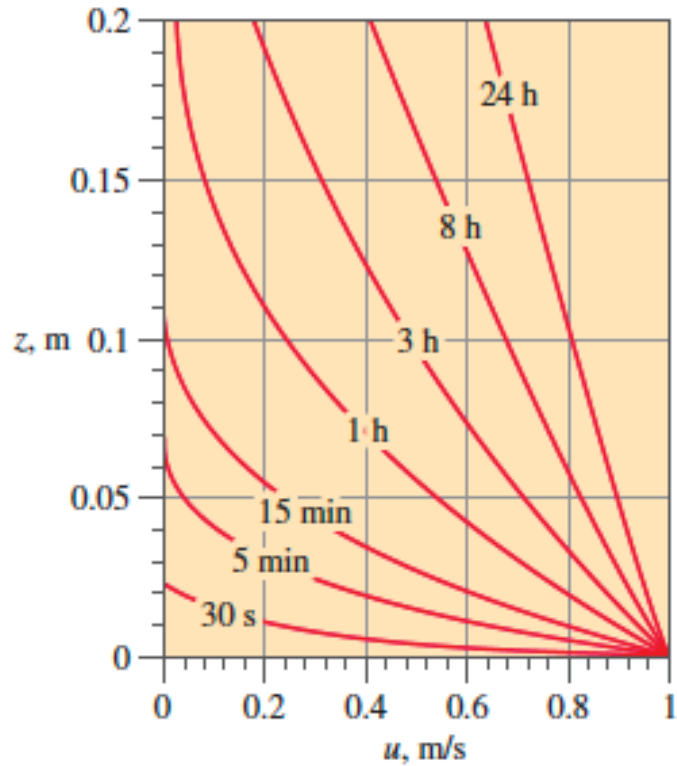

After 15 min of flow, the effect of the moving plate is not felt beyond about 10 cm above the plate!

water at room temperature ($\nu = 1.004 \times 10^{-6} \text{ m}^2/\text{s}$) with $V = 1.0 \text{ m/s}$

The time required for momentum to diffuse into the fluid seems much longer than we would expect.

This is because the solution presented here is **valid only for laminar flow**.

It turns out that if the plate's speed is large enough, or if there are significant vibrations in the plate or disturbances in the fluid, **the flow will become turbulent**.

In a turbulent flow, large eddies mix rapidly moving fluid near the wall with slowly moving fluid away from the wall.

This **mixing** process occurs rather quickly, so that turbulent diffusion is usually orders of magnitude faster than laminar diffusion.

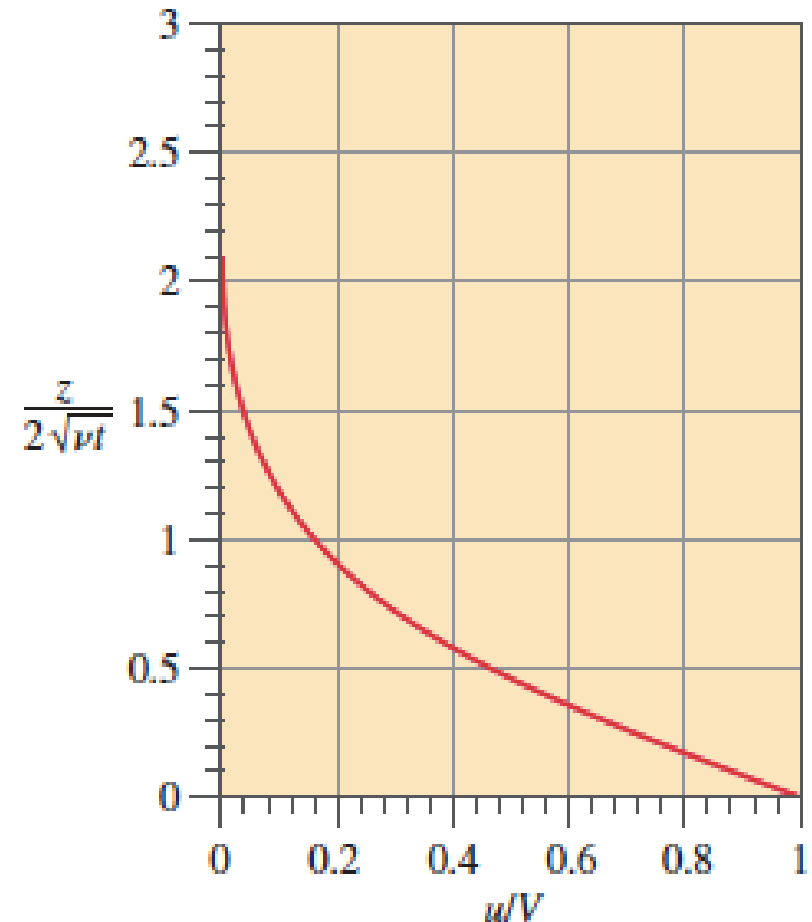

Non dimensionalized equations of motion

Our goal in this section is to nondimensionalize the equations of motion so that we can properly compare the orders of magnitude of the various terms in the equations. We begin with the incompressible continuity equation,

$$\vec{\nabla} \cdot \vec{V} = 0$$

and the vector form of the Navier–Stokes equation, valid for incompressible flow of a Newtonian fluid with constant properties,

$$\rho \frac{D\vec{V}}{Dt} = \rho \left[\frac{\partial \vec{V}}{\partial t} + (\vec{V} \cdot \vec{\nabla}) \vec{V} \right] = -\vec{\nabla} P + \rho \vec{g} + \mu \nabla^2 \vec{V}$$

Scaling parameters used to nondimensionalize the continuity and momentum equations, along with their primary dimensions

Scaling Parameter	Description	Primary Dimensions
L	Characteristic length	{L}
V	Characteristic speed	{Lt ⁻¹ }
f	Characteristic frequency	{t ⁻¹ }
$P_0 - P_\infty$	Reference pressure difference	{mL ⁻¹ t ⁻² }
g	Gravitational acceleration	{Lt ⁻² }

$$\nabla_{(-)} \frac{\partial (-)}{\partial x} \sim \frac{1}{L} \Rightarrow \nabla(\dots) = \nabla^*(\dots) \cdot \frac{1}{L} \Rightarrow \nabla^* = \nabla \cdot L$$

We can define scaled variables:

$$\begin{aligned} \rightarrow t^* &= ft & \vec{x}^* &= \frac{\vec{x}}{L} & \vec{v}^* &= \frac{\vec{v}}{V} \Rightarrow \vec{\nabla} = V \cdot \vec{\nabla}^* \\ P^* &= \frac{P - P_\infty}{P_0 - P_\infty} & \vec{g}^* &= \frac{\vec{g}}{g} & \vec{\nabla}^* &= L \vec{\nabla} \leftarrow \end{aligned}$$

In terms of which the continuity and NS equations become

Nondimensionalized continuity:

$$\vec{\nabla}^* \cdot \vec{V}^* = 0$$

$$\nabla \cdot \vec{V} = 0 \Rightarrow \frac{\nabla^* \cdot (\vec{V}^* \cdot V)}{L} \Rightarrow \nabla^* \cdot \vec{V}^* = 0$$

$$\rho V f \frac{\partial \vec{V}^*}{\partial t^*} + \frac{\rho V^2}{L} (\vec{V}^* \cdot \vec{\nabla}^*) \vec{V}^* = -\frac{P_0 - P_\infty}{L} \vec{\nabla}^* P^* + \rho g \vec{g}^* + \frac{\mu V}{L^2} \nabla^{*2} \vec{V}^* \div \frac{eV}{L}$$

$$\underbrace{\left[\frac{fL}{V} \right]}_{St} \frac{\partial \vec{V}^*}{\partial t^*} + \underbrace{1}_{Eu} (\vec{V}^* \cdot \vec{\nabla}^*) \vec{V}^* = - \underbrace{\left[\frac{P_0 - P_\infty}{\rho V^2} \right]}_{Eu} \vec{\nabla}^* P^* + \underbrace{\left[\frac{gL}{V^2} \right]}_{\frac{1}{Fr^2}} \vec{g}^* + \underbrace{\left[\frac{\mu}{\rho VL} \right]}_{\frac{1}{Re}} \nabla^{*2} \vec{V}^*$$

Nondimensionalized Navier–Stokes:

$$\rightarrow [St] \frac{\partial \vec{V}^*}{\partial t^*} + (\vec{V}^* \cdot \vec{\nabla}^*) \vec{V}^* = -[Eu] \vec{\nabla}^* P^* + \left[\frac{1}{Fr^2} \right] \vec{g}^* + \left[\frac{1}{Re} \right] \nabla^{*2} \vec{V}^*$$

Thus, the relative importance of the terms in the NS equation depends only on the relative magnitudes of the dimensionless parameters in square brackets [] known as the Strouhal (St), Euler (Eu), Froude (Fr), and Reynolds (Re) numbers.

Dynamic similarity

- Since there are four dimensionless parameters, dynamic similarity between a model and a prototype requires all four of these to be the same for the model and the prototype ($St_{\text{model}} = St_{\text{prototype}}$, $Eu_{\text{model}} = Eu_{\text{prototype}}$, $Fr_{\text{model}} = Fr_{\text{prototype}}$, and $Re_{\text{model}} = Re_{\text{prototype}}$).

Ex: Túnel do vento

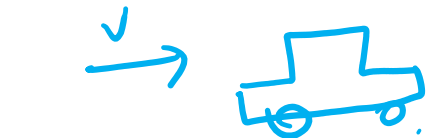

$$Re = \frac{L \cdot v}{\nu}$$



Prototype

$St_{\text{prototype}}$, $Eu_{\text{prototype}}$, $Fr_{\text{prototype}}$, $Re_{\text{prototype}}$

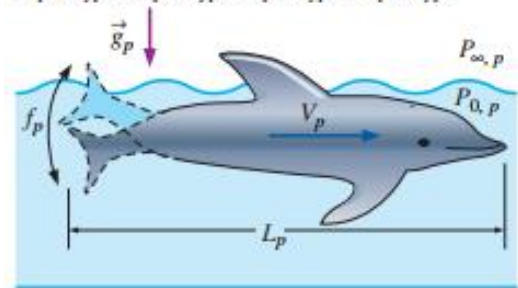

Model

St_{model} , Eu_{model} , Fr_{model} , Re_{model}

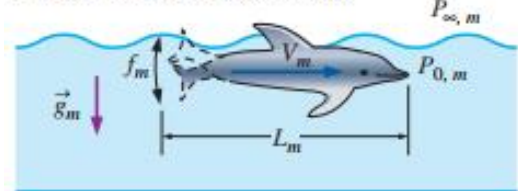

- If the flow is steady, then $f = 0$ and the Strouhal number drops out of the list of dimensionless parameters ($St = 0$). **If the characteristic frequency f is very small such that $St \ll 1$ the flow is called quasi-steady.** This means that at any instant in time (or at any phase of a slow periodic cycle), we can solve the problem as if the flow were steady, and the unsteady term again drops out.
- The effect of gravity is usually important only in flows with free-surface effects (e.g., waves, ship motion, spillways from hydroelectric dams, flow of rivers). For many engineering problems there is no free surface (pipe flow, fully submerged flow around a submarine or torpedo, automobile motion, flight of airplanes, birds, insects, etc.). In such cases, **the only effect of gravity on the flow dynamics is a hydrostatic pressure** distribution in the vertical direction superposed on the pressure field due to the fluid flow.

Modified pressure:

$$P' = P + \rho g z$$

- In terms of which the NS equation becomes

$$\rho \frac{D\vec{V}}{Dt} = \rho \left[\frac{\partial \vec{V}}{\partial t} + (\vec{V} \cdot \nabla) \vec{V} \right] = -\nabla P' + \mu \nabla^2 \vec{V}$$

Creeping flow (Stokes)

- Approximation of the class of fluid flow called creeping flow.
- Other names for this class of flow include Stokes flow and low Reynolds number flow.
- As the latter name implies, these are flows in which the Reynolds number is very small ($Re \ll 1$).
- By inspection of the definition of the Reynolds number, $Re = \rho VL/\mu$, we see that creeping flow is encountered when either ρ , V , or L is very small or viscosity is very large (or some combination of these).

$$Re = \frac{L \cdot V}{\nu}$$

$$\mu = \rho \cdot \nu$$



Stokes flow

- Another example of creeping flow is all around us and inside us, although we can't see it, namely, flow around **microscopic organisms**. Microorganisms live their entire lives in the creeping flow regime since they are very small, their size being of order a few microns, and they move very slowly, even though they may move in air or swim in water with a viscosity that can hardly be classified as "large". $\mu_{\text{air}} \cong 18.5 \mu\text{N}\cdot\text{s}/\text{m}^2$ and $\mu_{\text{water}} \cong 1.002 \text{ mN}\cdot\text{s}/\text{m}^2$ at room temperature – for comparison, $\mu_{\text{honey}} \cong 6 \text{ N}\cdot\text{s}/\text{m}^2$.
- Salmonella bacterium swimming through water. The bacterium's body is only about $1 \mu\text{m}$ long; its flagella (hairlike tails) extend several microns behind the body and serve as its propulsion mechanism. The Reynolds number associated with its motion is much smaller than 1 (typically, $\text{Re} = 10^{-5} - 10^{-4}$).



(a)

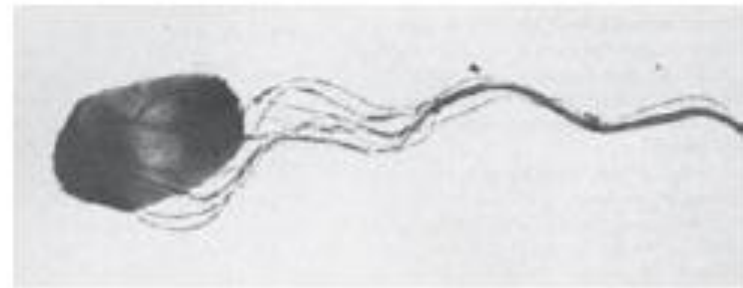

(b)

Stokes flow

- For simplicity, we assume that gravitational effects are negligible, or that they contribute only to a hydrostatic pressure component, as discussed previously.
- We also assume either steady flow or oscillating flow, with a Strouhal number of order unity ($St < 1$) or smaller, so that the unsteady acceleration term is orders of magnitude smaller than the viscous term $[1/Re]$ (the Reynolds number is very small).
- The advective term is of order 1, so this term drops out as well.

Thus, we ignore the entire left side of NS, which reduces to

Nondimensionalized Navier–Stokes:

$$[St] \frac{\partial \vec{V}^*}{\partial t^*} + (\vec{V}^* \cdot \nabla^*) \vec{V}^* = -[Eu] \nabla^* P^* + \left[\frac{1}{Fr^2} \right] \vec{g}^* + \left[\frac{1}{Re} \right] \nabla^{*2} \vec{V}^*$$

Handwritten annotations: ≈ 0 (under $[St]$), ≈ 0 (under $(\vec{V}^* \cdot \nabla^*) \vec{V}^*$), ≈ 0 (under $[Eu]$), ≈ 0 (under $[1/Re]$), ≈ 0 (under $\nabla^{*2} \vec{V}^*$), *com viscosidade* (near $[1/Re]$), *LL termo* (near $[1/Re]$)

Creeping flow approximation:

$$[Eu] \nabla^* P^* \cong \left[\frac{1}{Re} \right] \nabla^{*2} \vec{V}^*$$

Approximate Navier–Stokes equation for creeping flow:

$$\vec{\nabla} P \cong \mu \nabla^2 \vec{V}$$

You rely on inertia when you swim. For example, you take a stroke, and then you are able to glide for some distance before you need to take another stroke. When you swim, the inertial terms in the Navier–Stokes equation are much larger than the viscous terms, since the Reynolds number is very large.

For microorganisms swimming in the creeping flow regime, however, there is negligible inertia, and thus no gliding is possible. In fact, the lack of inertial terms has a substantial impact on how microorganisms are designed to swim. A flapping tail like that of a dolphin would get them nowhere. Instead, their long, narrow tails (flagella) undulate in a sinusoidal motion to propel them forward, as illustrated for a sperm. Without any inertia, the sperm does not move unless his tail is moving. The instant his tail stops, the sperm stops moving.

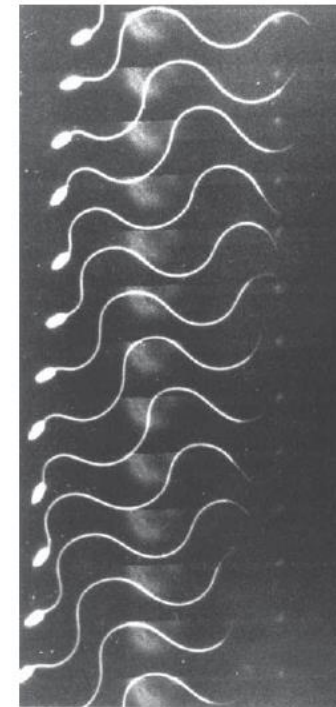

10 μm

Consequences of kinetic reversibility

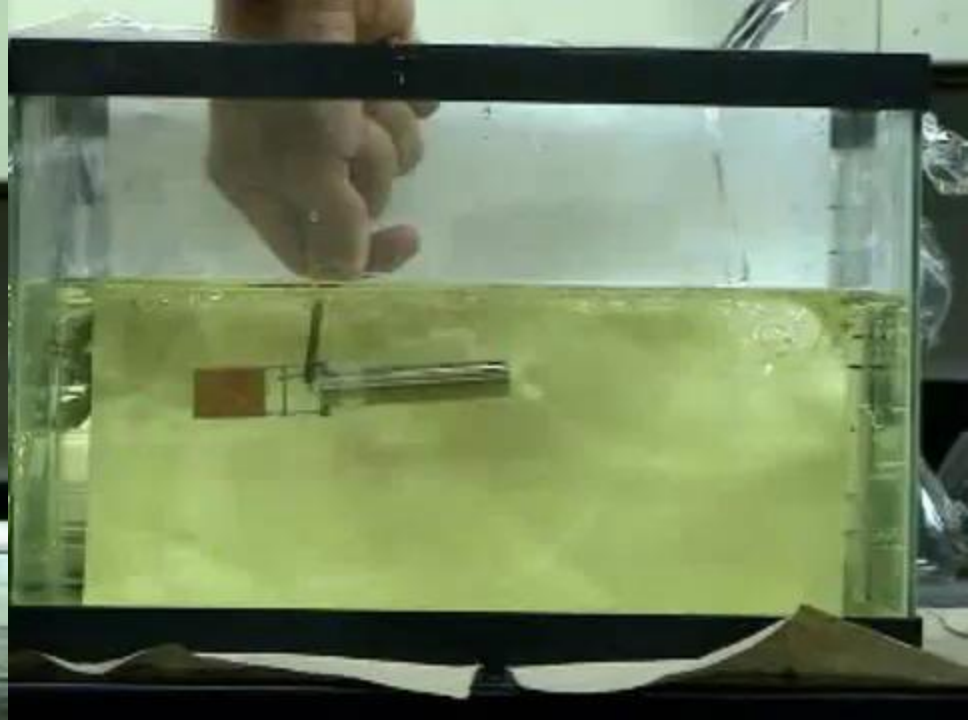

How do micro-scale organisms swim?

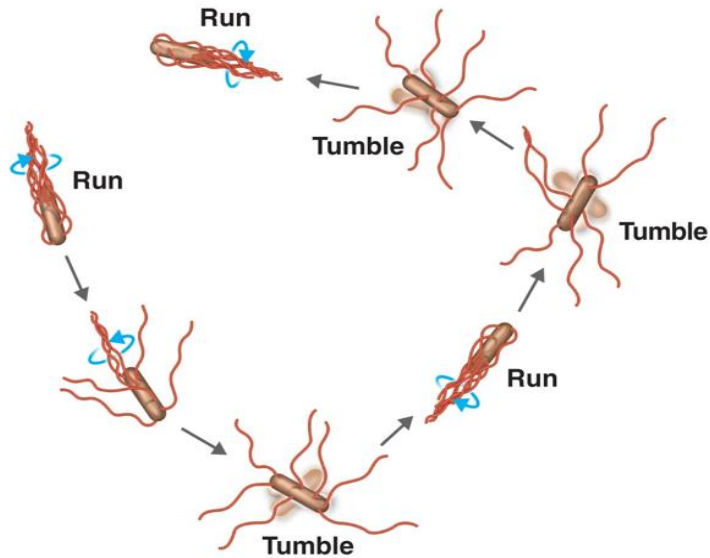

Microbiology: an introduction. G. Tortora et al., Pearson (2016)

Reynolds number = 10^{-5}



Equivalent to a human swimming on hot tar

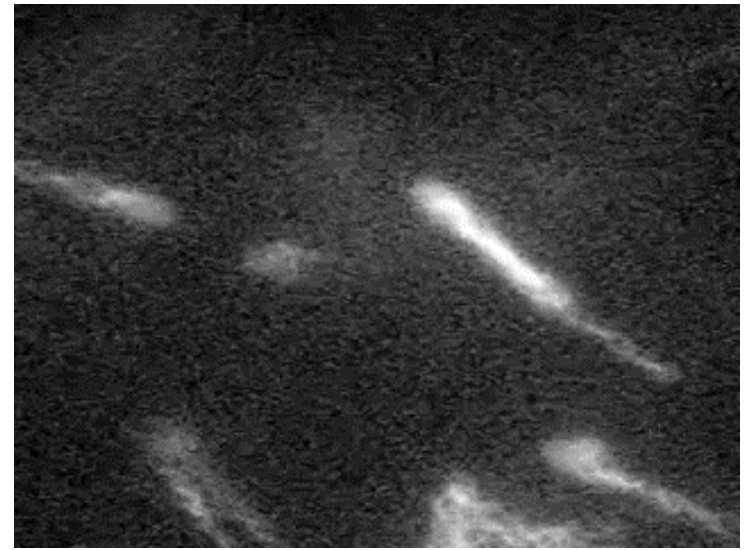

From Howard C. Berg's WEB site



Brad Nelson, Robotics and Intelligent Systems at ETH Zürich

Time-reversibility of Stokes Flow

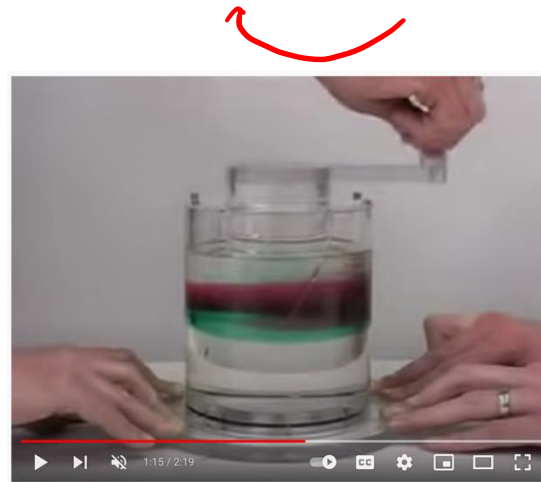

https://www.youtube.com/watch?v=p08_KITKP50

Time-reversibility of Stokes Flows: Dye has been injected into a viscous fluid sandwiched between two concentric cylinders (top panel). The core cylinder is then rotated to shear the dye into a spiral as viewed from above. The dye appears to be mixed with the fluid viewed from the side (middle panel). The rotation is then reversed bringing the cylinder to its original position. The dye "unmixes" (bottom panel). Reversal is not perfect because some diffusion of dye occurs.

Drag in Stokes flow

Drag force on a sphere in creeping flow:

$$F_D = 3\pi\mu VD$$

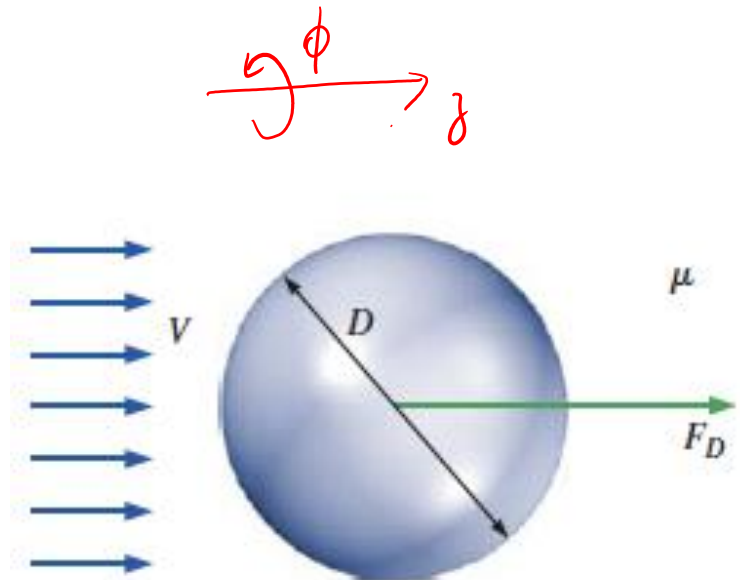
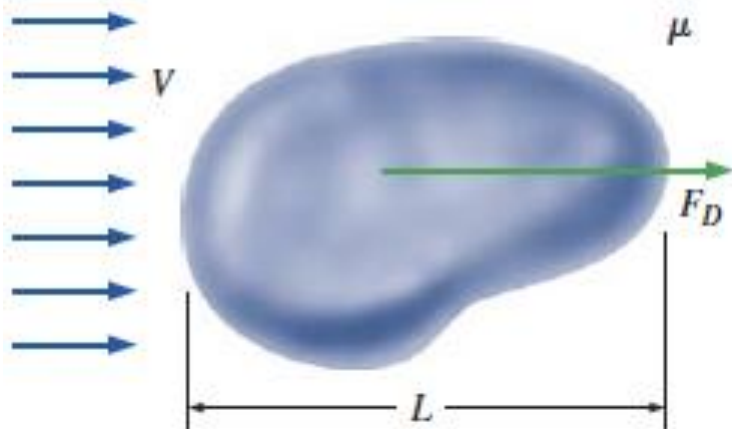

Stokes stream function

(Acheson, page 173)

For axisymmetric incompressible flow, we can write in spherical coordinates:

$$\nabla \cdot \vec{u} = 0$$

- Newtonian
- $\frac{\partial (\dots)}{\partial t} = 0$

$$\vec{u} = \nabla \wedge \left(\frac{\Psi}{r \sin \theta} \vec{e}_\phi \right)$$

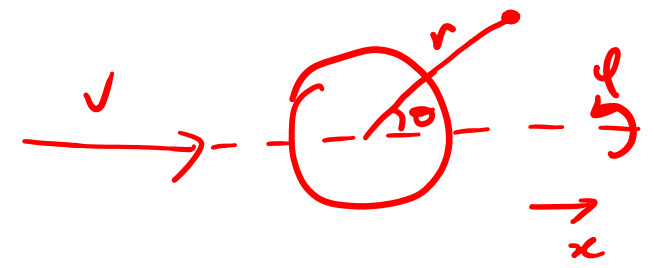

- $u_\phi = 0$
- $\frac{\partial \vec{u}}{\partial t} = 0$

$$u_r = \frac{1}{r^2 \sin \theta} \frac{\partial \Psi}{\partial \theta}, \quad u_\theta = -\frac{1}{r \sin \theta} \frac{\partial \Psi}{\partial r}$$

The Stokes stream function is constant along streamlines:

$$\frac{D\Psi}{Dt} = \frac{\partial \Psi}{\partial t} + (\vec{u} \cdot \nabla) \Psi = u_r \frac{\partial \Psi}{\partial r} + \frac{u_\theta}{r} \frac{\partial \Psi}{\partial \theta} = 0$$

$\Psi = \text{cte}$ so
 along de vms
 lignes de courante

Stokes flow around a sphere

(Acheson, page 223)

Axisymmetric flow

$$\mathbf{u} = [u_r(r, \theta), u_\theta(r, \theta), 0]$$

$\mu\phi = 0$

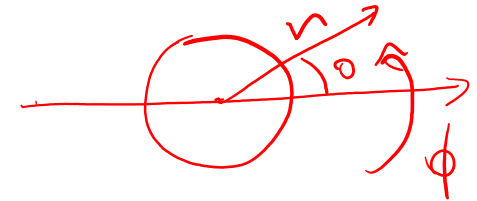

By using the Stokes stream function, we automatically satisfy the continuity equation ($\text{div } \mathbf{V} = 0$)

$$u_r = \frac{1}{r^2 \sin \theta} \frac{\partial \Psi}{\partial \theta}, \quad u_\theta = -\frac{1}{r \sin \theta} \frac{\partial \Psi}{\partial r}$$

Then

$$\nabla \wedge \mathbf{u} = \left[0, 0, \underbrace{(\nabla \times \mathbf{u})}_\phi \right]$$

where

$$E^2 = \frac{\partial^2}{\partial r^2} + \frac{\sin \theta}{r^2} \frac{\partial}{\partial \theta} \left(\frac{1}{\sin \theta} \frac{\partial}{\partial \theta} \right)$$

NS in the Stokes regime

$$\vec{\nabla} P \equiv \mu \nabla^2 \vec{V} \quad \rightarrow \quad \nabla p = -\mu \nabla \wedge (\nabla \wedge \mathbf{u})$$

since $\nabla \wedge (\nabla \wedge \mathbf{u}) = \underbrace{\nabla(\nabla \cdot \mathbf{u})}_{=0} - \nabla^2 \mathbf{u}$

We obtain

$$\left\{ \begin{array}{l} \text{Comp. } r \\ \frac{\partial p}{\partial r} = \frac{\mu}{r^2 \sin \theta} \frac{\partial}{\partial \theta} E^2 \Psi, \quad \frac{\partial(\dots)}{\partial \theta} \\ \text{comp. } \theta \\ \frac{1}{r} \frac{\partial p}{\partial \theta} = \frac{-\mu}{r \sin \theta} \frac{\partial}{\partial r} E^2 \Psi, \quad \frac{\partial}{\partial r}(r \times \dots) \end{array} \right. \quad \ominus$$

Eliminating the pressure cross derivatives we find

$$\rightarrow \boxed{E^2(E^2 \Psi) = 0}$$

*Eg. p/escormentos
nestejantos.*

$$\left[\frac{\partial^2}{\partial r^2} + \frac{\sin \theta}{r^2} \frac{\partial}{\partial \theta} \left(\frac{1}{\sin \theta} \frac{\partial}{\partial \theta} \right) \right]^2 \Psi = 0$$

Boundary condition at $r=a$: no slip

$$\vec{u} = 0$$

$$\left. \frac{\partial \Psi}{\partial r} \right|_{r=a} = \left. \frac{1}{r} \frac{\partial \Psi}{\partial \theta} \right|_{r=a} = 0$$

At infinity: $\vec{u} = U \hat{x}$

$$u_r \sim U \cos \theta \quad \text{and} \quad u_\theta \sim -U \sin \theta \quad \text{as } r \rightarrow \infty$$

$$\therefore \Rightarrow \Psi \sim \frac{1}{2} U r^2 \sin^2 \theta$$

Which suggests a solution of the form

$$\Psi = f(r) \sin^2 \theta$$

then

$$E^2(E^2\Psi) = 0 \quad \Rightarrow \quad \left(\frac{d^2}{dr^2} - \frac{2}{r^2} \right)^2 f = 0$$

$$f = r^\alpha$$

The solution is a polynomial in r , with the condition (use $f=r^\alpha$ in the previous equation):

$$[(\alpha - 2)(\alpha - 3) - 2][\alpha(\alpha - 1) - 2] = 0 \quad \alpha = -1, 1, 2, 4$$

→ $f(r) = \frac{A}{r} + Br + Cr^2 + Dr^4$

Uniform flow at infinity: $C = \frac{1}{2}U$ and $D = 0$ $f(r \rightarrow \infty) = \frac{1}{2}Uv^2$

pl \vec{u} sen finito con $r \rightarrow \infty$

At $r=a$, $f(a) = f'(a) = 0$ $A = \frac{a^3U}{4}$, $B = -\frac{3}{4}aU$

We find

$$\Psi = \frac{1}{4}U \left(2r^2 + \frac{a^3}{r} - 3ar \right) \sin^2 \theta$$

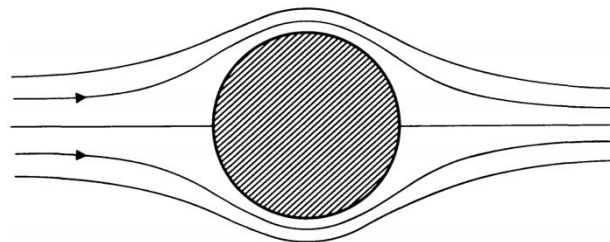

Fig. 7.2. Low Reynolds number flow past a sphere.

Drag force

To calculate the pressure, we use

$$\frac{\partial p}{\partial r} = \frac{\mu}{r^2 \sin \theta} \frac{\partial}{\partial \theta} E^2 \Psi,$$

$$\frac{1}{r} \frac{\partial p}{\partial \theta} = \frac{-\mu}{r \sin \theta} \frac{\partial}{\partial r} E^2 \Psi,$$

For the previous streamfunction:

$$E^2 \Psi = \frac{3}{2} U a r^{-1} \sin^2 \theta$$

Integrating

$$p = p_\infty - \frac{3}{2} \frac{\mu U a}{r^2} \cos \theta$$

Stress components in spherical coordinates

$$t_r = T_{rr} = -p + 2\mu \frac{\partial u_r}{\partial r}, \quad t_r = T_{rr} m_r + T_{r\theta} m_\theta + T_{r\phi} m_\phi, \quad \hat{n} = \hat{r}$$

$$t_\theta = T_{r\theta} = \mu r \frac{\partial}{\partial r} \left(\frac{u_\theta}{r} \right) + \frac{\mu}{r} \frac{\partial u_r}{\partial \theta},$$

$$T_{ij} = -P \delta_{ij} + 2\mu \epsilon_{ij}$$

$\epsilon = \sigma_{ij}$ (notação de Achenbach)

$$t_\phi = T_{r\phi} = 0,$$

Calculate the velocity using the stream function

$$u_r = \frac{1}{r^2 \sin \theta} \frac{\partial \Psi}{\partial \theta}, \quad u_\theta = -\frac{1}{r \sin \theta} \frac{\partial \Psi}{\partial r}$$

Using the streamfunction, we can calculate the velocity field and the stress components

$$t_r = -p_\infty + \frac{3}{2} \frac{\mu U}{a} \cos \theta, \quad t_\theta = -\frac{3}{2} \frac{\mu U}{a} \sin \theta.$$

By symmetry, we expect the net force on the sphere to be on the direction of the uniform stream, and the appropriate component of the stress is

$$t = t_r \cos \theta - t_\theta \sin \theta = -p_\infty \cos \theta + \frac{3}{2} \frac{\mu U}{a}$$

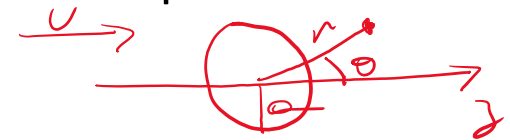

$$\hat{z} = \cos \theta \hat{r} - \sin \theta \hat{\theta}$$

Recall. See Acheson's appendix

The components of the rate-of-strain tensor are given by:

$$\begin{aligned}e_{rr} &= \frac{\partial u_r}{\partial r}, & e_{\theta\theta} &= \frac{1}{r} \frac{\partial u_\theta}{\partial \theta} + \frac{u_r}{r}, \\e_{\phi\phi} &= \frac{1}{r \sin \theta} \frac{\partial u_\phi}{\partial \phi} + \frac{u_r}{r} + \frac{u_\theta \cot \theta}{r}, \\2e_{\theta\phi} &= \frac{\sin \theta}{r} \frac{\partial}{\partial \theta} \left(\frac{u_\phi}{\sin \theta} \right) + \frac{1}{r \sin \theta} \frac{\partial u_\theta}{\partial \phi}, & (A.44) \\2e_{\phi r} &= \frac{1}{r \sin \theta} \frac{\partial u_r}{\partial \phi} + r \frac{\partial}{\partial r} \left(\frac{u_\phi}{r} \right), \\2e_{r\theta} &= r \frac{\partial}{\partial r} \left(\frac{u_\theta}{r} \right) + \frac{1}{r} \frac{\partial u_r}{\partial \theta}.\end{aligned}$$

The drag on the sphere is therefore

$$D = \int_0^{2\pi} \int_0^\pi \underbrace{a^2 \sin \theta \, d\theta \, d\phi}_{dA} = 6\pi\mu Ua.$$

This is the Stokes law. This is valid for low Re (measurements start to deviate from Stokes law for $Re = 0.5$).

For a ball falling through a viscous liquid, we also have the buoyancy force

$$6\pi\mu U_T a = \frac{4}{3}\pi a^3 (\rho_{\text{sphere}} - \rho_{\text{fluid}})g.$$

Stokes flow around a sphere (alternative derivation)

Faber

When its inertial term is neglected, the Navier–Stokes equation becomes

$$-\nabla p^* - \eta \nabla \wedge (\nabla \wedge \mathbf{u}) = 0, \quad (6.63)$$

which, since

$$\nabla \wedge (\nabla \wedge \mathbf{u}) = \nabla(\nabla \cdot \mathbf{u}) - \nabla^2 \mathbf{u},$$

is equivalent for an effectively incompressible fluid such that $\nabla \cdot \mathbf{u}$ is zero to

$$\nabla^2 \mathbf{u} = \frac{1}{\eta} \nabla p^*. \quad (6.64)$$

This is the basic equation of motion for creeping flow. Its solutions for \mathbf{u} consist in general of a *particular integral*, \mathbf{u}_{PI} , and a *complementary function*, \mathbf{u}_{CF} . The latter is a solution of $\nabla^2 \mathbf{u} = 0$, which means that it is normally a solution of $\nabla \wedge \mathbf{u} = 0$ and can therefore be described by a potential ϕ_{CF} . In the present problem the complementary function has to be chosen in such a way that it corresponds to uniform flow in the x_1 direction at large distances from the sphere, so in the spherical polar coordinates defined in fig. 4.6 we may expect [§4.7]

$$\phi_{\text{CF}} = UR \cos \theta + AR^{-2} \cos \theta,$$

or

$$\begin{aligned}u_{R,CF} &= (U - 2AR^{-3}) \cos \theta, \\u_{\theta,CF} &= (-U - AR^{-3}) \sin \theta,\end{aligned}$$

where the coefficient A remains to be determined.

We cannot hope to match the boundary condition that $\mathbf{u} = 0$ at $R = a$ for all values of θ unless $u_{R,PI}$ and $u_{\theta,PI}$ are likewise proportional to $\cos \theta$ and $\sin \theta$ respectively. But application of the divergence operator ($\nabla \cdot$) to (6.63) shows at once that p^* obeys Laplace's equation,

$$\nabla^2 p^* = 0. \quad (6.65)$$

Where the flow is axially symmetric, as it is here, p^* must therefore be expressible, like ϕ_{CF} , in solid harmonic functions. If it is defined to be zero at large values of R where $\mathbf{u} = U$, then the only credible possibility is that

$$p^* = BR^{-2} \cos \theta, \quad (6.66)$$

where the coefficient B is independent of θ and R . In that case ∇p^* is proportional to R^{-3} , and \mathbf{u}_{PI} must therefore be proportional to R^{-1} . Let us try

$$u_{R,PI} = CR^{-1} \cos \theta.$$

Then in order to satisfy the condition

$$\nabla \cdot \mathbf{u}_{PI} = \frac{1}{R^2} \frac{\partial(R^2 u_{R,PI})}{\partial R} + \frac{1}{R \sin \theta} \frac{\partial(\sin \theta u_{\theta,PI})}{\partial \theta} = 0$$

we must set

$$u_{\theta,PI} = -\frac{1}{2} CR^{-1} \sin \theta.$$

These guesses have now to be checked by substitution into (6.64). Both sides of that equation are, of course, vectors, but to simplify the analysis we shall consider only their components in the longitudinal x_1 direction; it can easily be verified that when these are equal to one another the transverse components are equal to one another also. On the left-hand side we have

$$\nabla^2 u_{1,PI} = \left\{ \frac{1}{R^2} \frac{\partial}{\partial R} \left(R^2 \frac{\partial}{\partial R} \right) + \frac{1}{R^2 \sin \theta} \frac{\partial}{\partial \theta} \left(\sin \theta \frac{\partial}{\partial \theta} \right) \right\} (u_R \cos \theta - u_\theta \sin \theta),$$

which simplifies to

$$\begin{aligned} \nabla^2 u_{1,PI} &= \frac{1}{2} C \frac{1}{R^3 \sin \theta} \frac{\partial}{\partial \theta} \left\{ \sin \theta \frac{\partial}{\partial \theta} (2 \cos^2 \theta + \sin^2 \theta) \right\} \\ &= -\frac{C}{R^3} (2 \cos^2 \theta - \sin^2 \theta). \end{aligned}$$

On the right-hand side we have

$$\begin{aligned}\frac{1}{\eta} \frac{\partial p^*}{\partial x_1} &= \frac{1}{\eta} \left(\cos \theta \frac{\partial p^*}{\partial R} - \frac{1}{R} \sin \theta \frac{\partial p^*}{\partial \theta} \right) \\ &= -\frac{B}{\eta R^3} (2 \cos^2 \theta - \sin^2 \theta).\end{aligned}$$

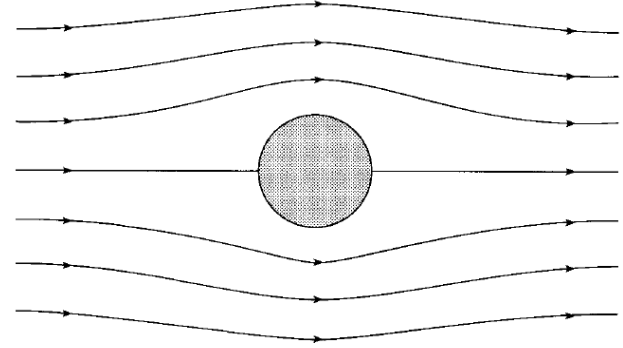

Figure 6.12 Lines of flow past a sphere according to Stokes's solution.

These expressions can indeed be made equal to one another, by choosing $C = B/\eta$. Finally, to ensure that both u_R and u_θ vanish at $R = a$ we need to let $A = -\frac{1}{4}a^3U$, $C = -\frac{3}{2}aU$.

The full solution, which is the only solution which satisfies the given boundary conditions, is therefore

$$\begin{aligned}u_R &= u_{R,CF} + u_{R,PI} = U \cos \theta \left(1 - \frac{3a}{2R} + \frac{a^3}{2R^3} \right), \\ u_\theta &= u_{\theta,CF} + u_{\theta,PI} = -U \sin \theta \left(1 - \frac{3a}{4R} - \frac{a^3}{4R^3} \right).\end{aligned}\tag{6.67}$$

The principal respects in which it differs from the solution of Euler's equation worked out in §4.7, on the basis of potential theory alone, are:

- (i) it satisfies the no-slip boundary condition at the sphere's surface;
- (ii) it describes a velocity u_θ in the equatorial ($\theta = \pi/2$) plane which increases monotonically towards U with increasing R instead of decreasing;
- (iii) the terms in a/R which it contains represent a perturbation of the flow field which is of a *long-range* nature.

Pressure

According to this solution, the excess stress which acts upon the surface of the sphere has a normal component given by

$$p_R^* = p^* - 2\eta \left(\frac{\partial u_R}{\partial R} \right)_{R=a} = - \frac{3\eta U \cos \theta}{2a},$$

[(6.11)] and a shear component acting in the direction of increasing θ given by

$$s_{\theta R} = \eta a \left\{ \frac{\partial}{\partial R} \left(\frac{u_\theta}{R} \right) + \frac{1}{a^2} \frac{\partial u_R}{\partial \theta} \right\}_{R=a} = - \frac{3\eta U \sin \theta}{2a}$$

[(6.3) and (6.53)]. Taken together, these components are equivalent to a uniform force per unit area in the direction of U of magnitude $3\eta U/2a$. The total drag force in the direction of U is therefore

$$F_D = 4\pi a^2 \frac{3\eta U}{2a} = 6\pi\eta a U. \quad (6.68)$$

This expression constitutes *Stokes's law*.

Discussion

It is only in the limit when velocity U and Reynolds Number $Re (= 2\rho aU/\eta)$ tend to zero that the assumption on which Stokes's law is based is fully consistent with the details of his solution. Since the leading term in \mathbf{u} is \mathbf{U} , while the next terms in (6.67) are proportional to aU/R , the inertial term in the Navier–Stokes equation, $\rho(\mathbf{u} \cdot \nabla)\mathbf{u}$, is of order $\rho U^2 a/R^2$ at large values of R according to Stokes, while the viscous term $\eta \nabla \wedge (\nabla \wedge \mathbf{u})$ is of order $\eta a U/R^3$. Far from being negligible, the inertial term is clearly liable to exceed the viscous term at distances such that

$$R > \frac{\eta}{\rho U} = \frac{2a}{Re}.$$

The inconsistency may suggest to the reader that we cannot trust equations (6.67) to describe the velocity distribution in the immediate vicinity of the sphere, and that we therefore cannot trust Stokes's law, unless Re is really quite small compared with unity. It is only when Re reaches about 0.5, however, that deviations from the law become detectable experimentally.

Needless to say, if Stokes's law applies in a frame of reference such that the sphere is stationary then it applies also in the frame in which the distant fluid is stationary and the sphere is moving instead. Thus a solid sphere of radius a and density ρ_{sol} , falling down the axis of a vertical cylinder of sufficiently large radius which is filled with liquid of density ρ_{liq} , may be expected to reach a terminal velocity U such that

$$6\pi\eta aU = \frac{4}{3}\pi a^3(\rho_{\text{sol}} - \rho_{\text{liq}})g, \quad (6.69)$$

provided that

$$Re = \frac{4a^3 \rho_{\text{liq}} (\rho_{\text{sol}} - \rho_{\text{liq}}) g}{9\eta^2} < 0.5. \quad (6.70)$$

If the falling sphere is itself liquid, with viscosity η' , circulating currents arise within it as it falls which modify the flow pattern outside the sphere. The modified form of Stokes's law which applies in these circumstances is

$$F_D = \frac{4\pi\eta a U (\eta + \frac{3}{2}\eta')}{\eta + \eta'}. \quad (6.71)$$

This evidently reduces to (6.68) when $\eta' \gg \eta$, e.g. under the conditions of Millikan's celebrated experiment, where the spheres were oil drops moving through air. At the opposite extreme where $\eta' \ll \eta$, however, e.g. where the spheres are very small bubbles of gas rising (rather than falling) through soda water or champagne, it reduces to $F_D = 4\pi\eta a U$, so the terminal velocity of such bubbles should be

$$U = \frac{a^2 \rho_{\text{liq}} g}{3\eta} \quad (6.72)$$

[(6.69), but with 6 replaced by 9 and with ρ_{sol} replaced by ρ_{gas} ; ρ_{gas} is negligible compared with ρ_{liq}]. In fact, (6.72) does not describe the terminal velocity of rising soda water bubbles at all accurately. That is partly because the Reynolds Number normally exceeds 0.5 but also, it seems, because impurities adsorbed on the gas-liquid interface endow this interface with some measure of rigidity. It can be shown, incidentally, that the stresses which act on a gas bubble which is rising steadily with $Re \ll 1$ do not tend to distort it; it should – and does – remain spherical.

Challenge: flowing droplet

$$\vec{V}_A = \vec{V}_B \quad \text{and} \quad \tau_{s,A} = \tau_{s,B}$$

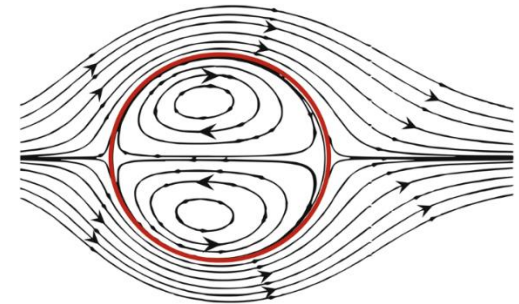

$$\eta' \gg \eta$$

<https://youtu.be/UFiPWv03f6g>

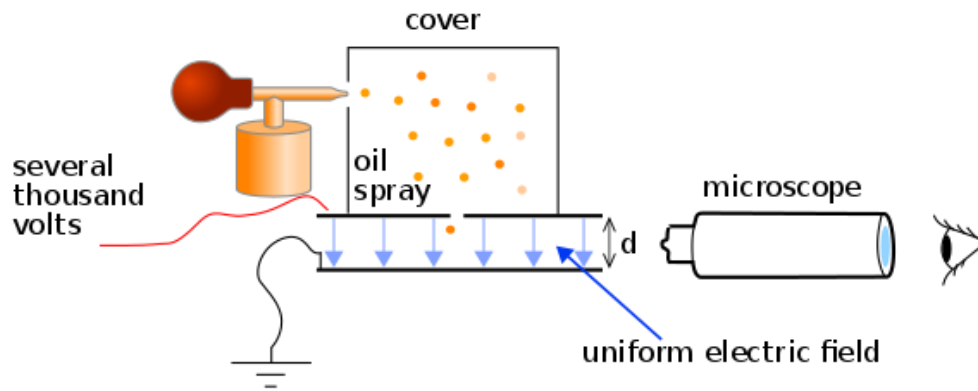

$$\eta' \ll \eta$$



Simple fluid simulations (exercises)

- Numerical solution of the Navier-Stokes equation;
- Lattice Boltzmann method (LBM): implements the Boltzmann equation and recovers the Navier-Stokes equation in the macroscopic limit;
- Use of python: not efficient, but practical and more didactic;
- Available at: <https://github.com/rcvcoelho/lbm-python.git>

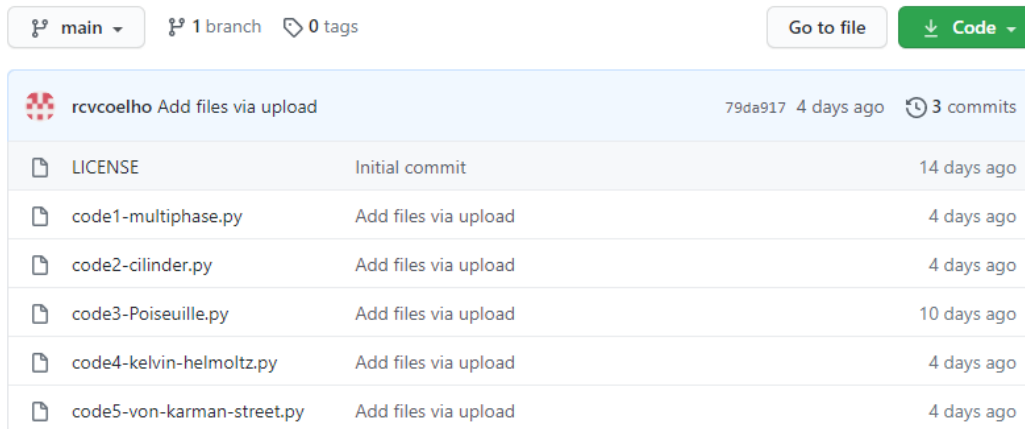

main 1 branch 0 tags

Go to file Code

rcvcoelho Add files via upload 79da917 4 days ago 3 commits

LICENSE	Initial commit	14 days ago
code1-multiphase.py	Add files via upload	4 days ago
code2-cilinder.py	Add files via upload	4 days ago
code3-Poiseuille.py	Add files via upload	10 days ago
code4-kelvin-helmoltz.py	Add files via upload	4 days ago
code5-von-karman-street.py	Add files via upload	4 days ago

Poiseuille 2D

$T=200$ (transient state). It becomes a parabola for longer times.

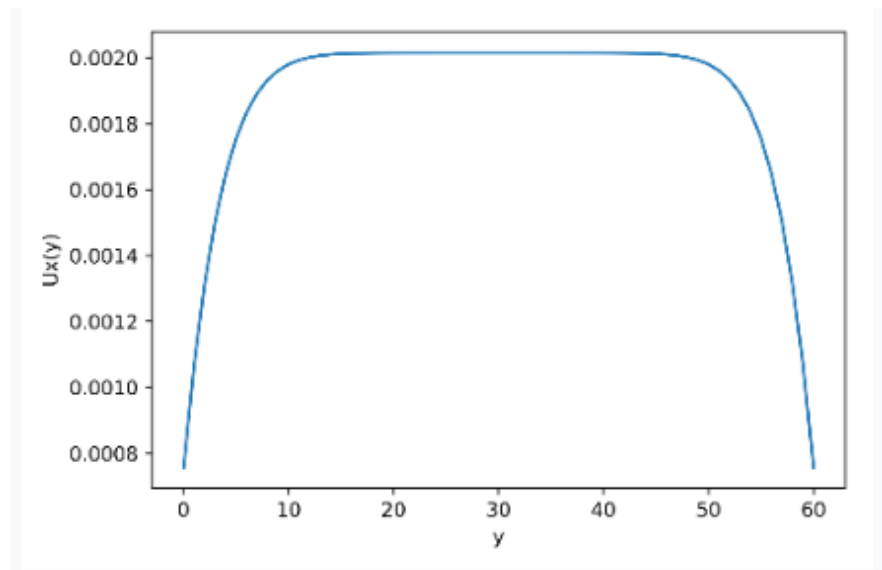
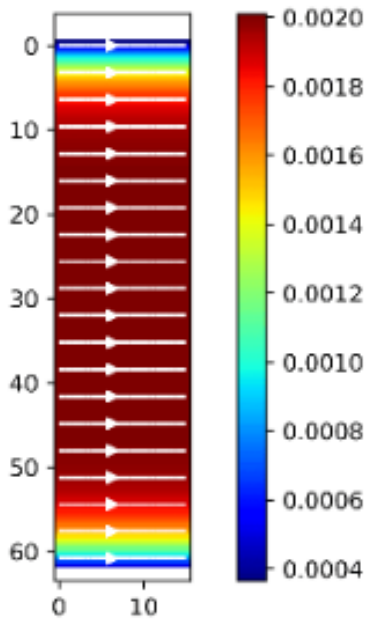

Cylinder

t=76700 steps

